

CECHO



**MOCNE
ZAWIESIA**

CECHO

MOCNE ZAWIESIA

www.CECHO.pl



Jesteśmy producentem wprowadzającym zupełnie nową jakość na polskim rynku oferując zawiesia, osprzęt do podnoszenia ładunków i systemy mocowania w transporcie. W naszym portfolio znajdziecie Państwo również bogaty pakiet szkoleń w zakresie bezpiecznej eksploatacji zawiesi oraz szeroki zakres świadczonych usług.

Marka Cecho powstała w oparciu o fachową wiedzę i wieloletnie doświadczenia wykwalifikowanej kadry inżynierów. W zależności od potrzeb klienta proponujemy zarówno sprawdzone produkty jak i innowacyjne rozwiązania.



W pracy z klientem skupiamy się na konkretach, a filozofię naszej marki można ująć w kilku słowach.



BEZPIECZNIE

Mając na uwadze, że bezpieczeństwo jest najważniejsze, oferujemy produkty i usługi najwyższej jakości. Nasi klienci otrzymują certyfikowane produkty spełniające wymagania aktualnych norm oraz dyrektywy maszynowej.

PROFESJONALNIE

Jesteśmy specjalistami w naszej dziedzinie. Wiedzę naszą zdobyliśmy dzięki wieloletniej pracy w branży połączonej z pasją podejmowania coraz to nowych wyzwań na płaszczyźnie zawodowej.



KOMPLEKSOWO

Począwszy od doradztwa, poprzez zaoferowanie optymalnych rozwiązań, dostarczenie odpowiednich produktów, wdrożenie ich u klienta, następnie kontrolę szczegółową, serwis i szkolenie operatorów zaspokajamy potrzeby klientów.

RZETELNIE i TERMINOWO

Wiemy, że w obliczu rosnących oczekiwań klienta, terminowość i czas realizacji zamówienia są kluczowe. Dlatego dysponujemy zapleczem produkcyjno-magazynowym, a wypracowana przez lata sieć kontaktów z naszymi partnerami pozwala w sposób szybki i profesjonalny zrealizować Państwa zamówienia.



SPIS TREŚCI

ZAWESIA ŁAŃCUCHOWE.....	2
ZAWESIA LINOWE.....	8
ZAWESIA PASOWE.....	12
ZAWESIA WĘŻOWE.....	16
ODCIĄGI ŁAŃCUCHOWE.....	18
PASY MOCUJĄCE/ŚRODKI DO MOCOWANIA ŁADUNKU.....	19
AKCESORIA ZAWESIOWE KLASA 8.....	22
AKCESORIA ZAWESIOWE KLASA 10.....	30
AKCESORIA ZAWESIOWE KLASA 12.....	51
AKCESORIA ZAWESIOWE NIERDZEWNE.....	59
SZAKLE.....	64
POZOSTAŁE AKCESORIA ZAWESIOWE.....	71
PUNKTY MOCUJĄCE.....	78
UCHWYTY, CHWYTAKI.....	85
WCIĄGNIKI, WÓZKI, PODNOŚNIKI.....	92
ZBLOCZA, KRAŻKI.....	97
TRAWERSY.....	100
SUWNICE, ŻURAWIE.....	102
LINY STALOWE.....	104

*Przedstawiona oferta ma charakter informacyjny i nie stanowi oferty handlowej w rozumieniu Art.66 par.1 Kodeksu Cywilnego

ZAWESIA ŁAŃCUCHOWE

- Spełniają wymagania dyrektywy maszynowej 2006/42/WE oraz zharmonizowanej normy PN-EN 818-4
- Współczynnik bezpieczeństwa: 4
- Użyte materiały: łańcuch w klasie 12, 10, 8 lub 6 stali, komponenty w klasie 12, 10, 8 lub 6 stali. Dostępne także zawiesia w klasie 4 przeznaczone do ocynkowni.
- Łańcuch zabezpieczony przed korozją, komponenty malowane proszkowo
- Połączenia wykonane na złączkach umożliwiają dokonanie napraw i regeneracji (dostępne zawiesia zgrzewane)
- Długość zawiesia wg. zamówienia klienta, mierzona między punktami nośnymi „L”
- Znakowanie: udźwig, znak CE, nazwa/symbol producenta, numer seryjny, długość robocza zawiesia, data produkcji
- Dokumenty: deklaracja zgodności, świadectwo jakości 2.1, instrukcja użytkowania.

KLASA 8

- Użyte materiały: łańcuch w klasie 8 stali, komponenty w klasie 8 stali (wytrzymałość na rozciąganie 800 N/mm²)

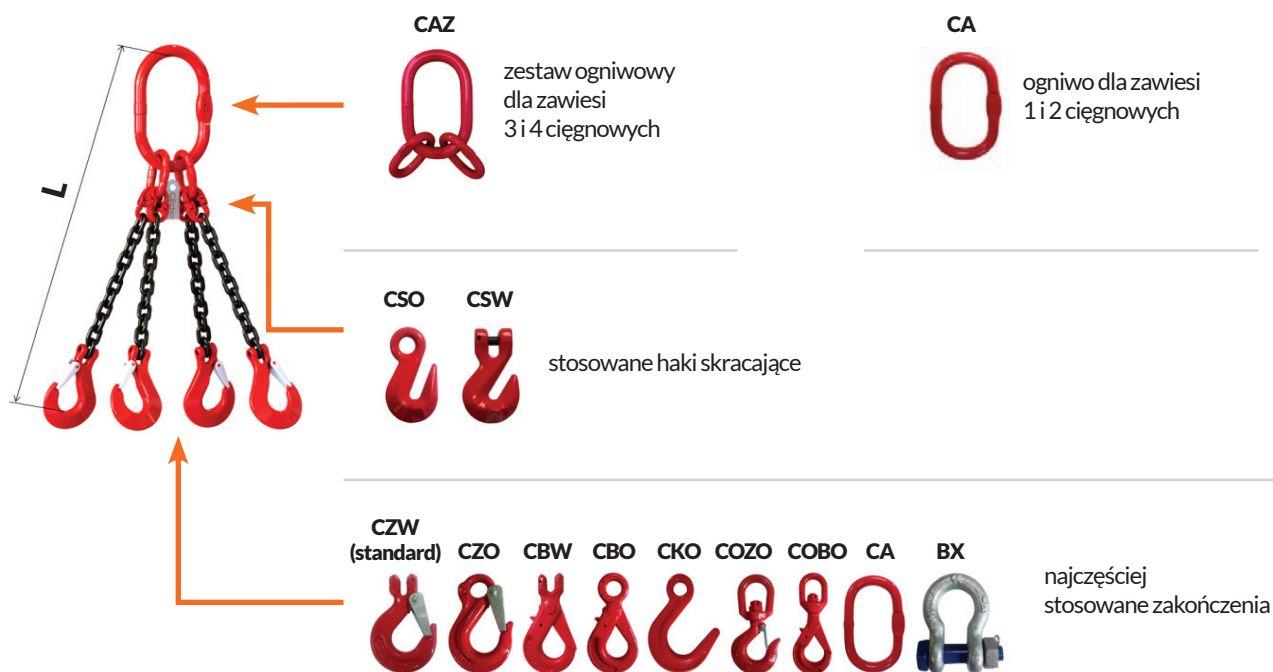

KLASA 10

- Użyte materiały: łańcuch w klasie 10 stali, komponenty w klasie 10 stali (wytrzymałość na rozciąganie 1000 N/mm²)
- 25% większy udźwieg w stosunku do klasy 8 zawiesi przy zachowaniu tej samej wagi zawiesia
- Zwiększona odporność na ścieranie a tym samym dłuższa żywotność zawiesia

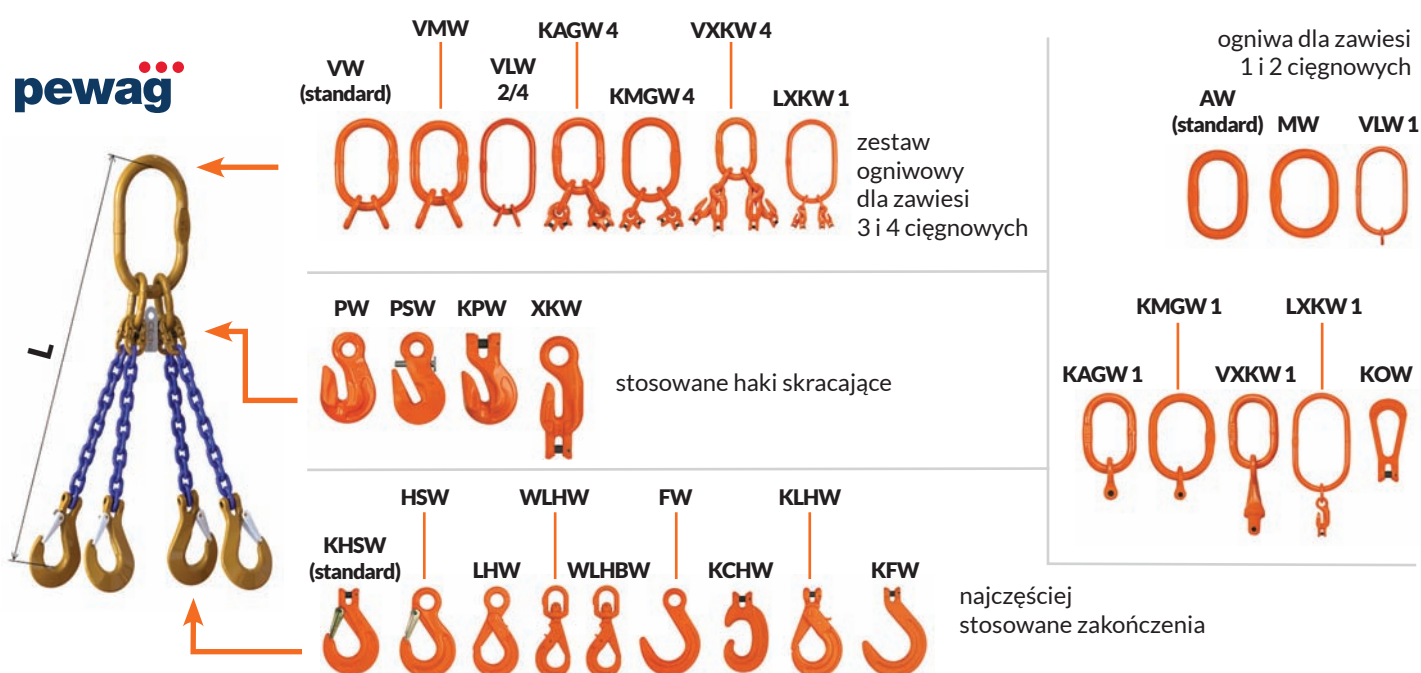

KLASA 12

- Użyte materiały: łańcuch w klasie 12 stali, komponenty w klasie 12 stali (wytrzymałość na rozciąganie 1200 N/mm²)
- Większy o 25% udźwig w stosunku do klasy 10 a 50% większy udźwig w stosunku do klasy 8 zawiesi przy zachowaniu tej samej wagi zawiesia
- Znacząca redukcja ciężaru (40% w stosunku do kl. 8) umożliwia wygodne użytkowanie zawiesia
- Zwiększona odporność na ścieranie, a tym samym dłuższa żywotność zawiesia

pewag

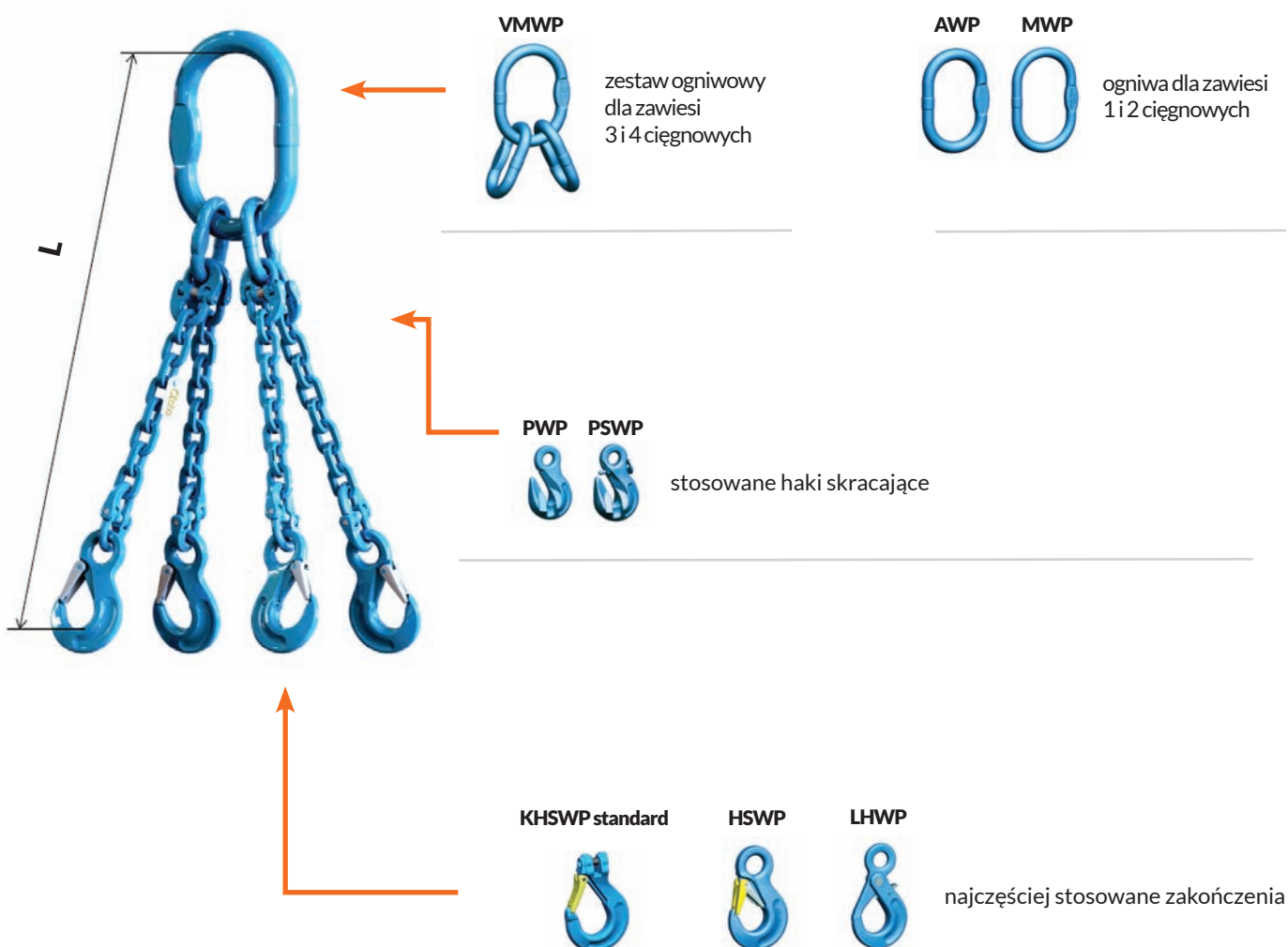

ZAWIESIA ZE STALI NIERDZEWNEJ

- Użyte materiały: łańcuch WOX w klasie 6 stali nierdzewnej, elektrycznie zgrzewany i znakowany, komponenty w klasie 6 stali nierdzewnej (wytrzymałość na rozciąganie 630 N/mm²) Produkty oparte są na materiale 1.4571 (AISI 316 Ti) oraz 1.4404 (AISI 316L) i 1.4462 (AISI 318 LN) ze zredukowaną zawartością węgla
- Odpowiedni dobór gatunków stali pozwolił na uzyskanie zawiesi które mogą pracować w agresywnym środowisku bez narażenia zawiesia na korozję i zniszczenie
- Rozwiązanie to jest szczególnie dedykowane do takich gałęzi przemysłu jak: oczyszczalnie ścieków, przepompownie, przemysł chemiczny, elektrownie, przemysł morski, place zabaw, przemysł spożywczy i inne

pewag

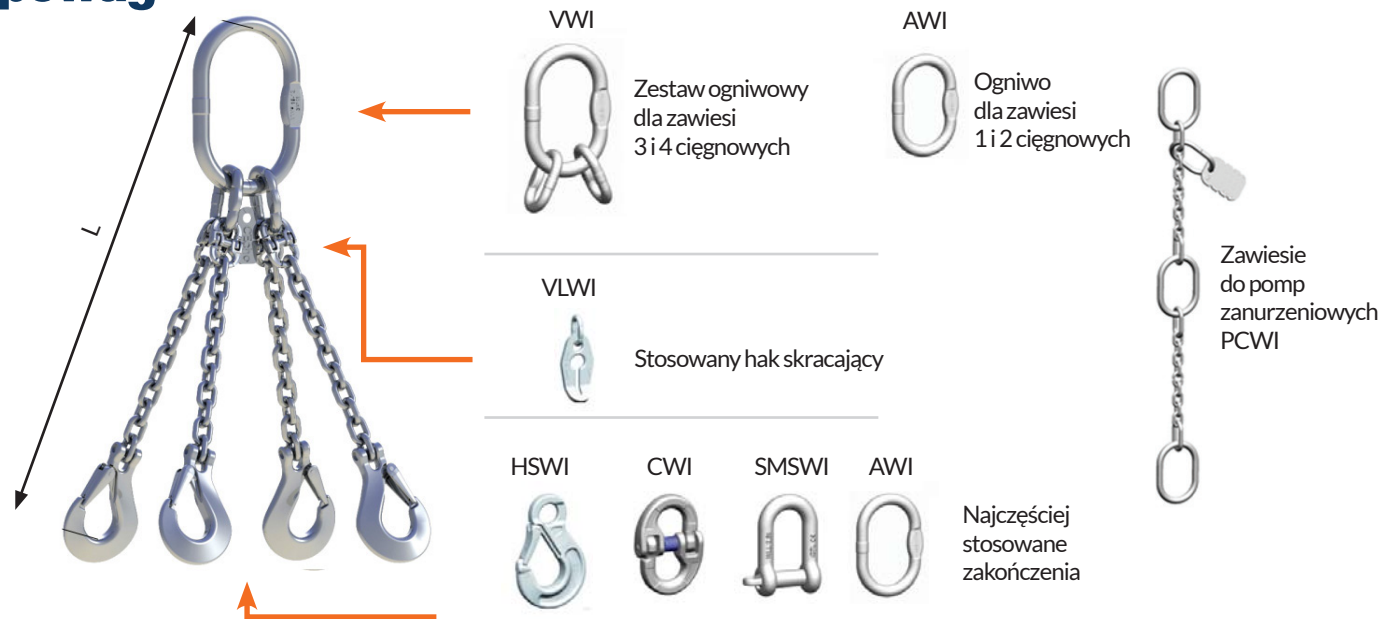

PODSTAWOWE WARUNKI PRACY REDUKUJĄCE UDŹWIG ZAWIESIA





Temperatura pracy



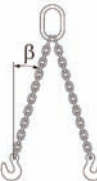

klasa łańcucha	-40° - 200°C	200° - 300°C	300° - 400°C	400 - 475°C	475 - 600°C	600 - 700°C	powyżej 700°C
4		100%				niedozwolone	
8	100%	90%	75%			niedozwolone	
10	100%				niedozwolone		
12	100%	60%			niedozwolone		

Ostre krawędzie

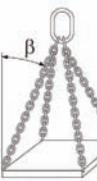
	R większe niż 2 x średnica łańcucha	R większe niż średnica łańcucha	R równy średnicy łańcucha lub mniejszy
krawędzie			
mnożnik	1	0,7	0,5

ZAWIESIA ŁAŃCUCHOWE

współczynnik bezpieczeństwa		1-ciężnowe		2-ciężnowe		3 i 4 ciężnowe	
4							
	kąt rozwarcia	-	-	0° do 45°	45° do 60°	0° do 45°	45° do 60°
współczynnik obciążenia		1	0,8	1,4	1	2,1	1,5
klasa zawiesia	rozmiar łańcucha					Udźwig zawiesia w [t]	
8	6	1,12	0,90	1,60	1,12	2,36	1,70
	7	1,50	1,20	2,12	1,50	3,15	2,24
	8	2,00	1,60	2,80	2,00	4,25	3,00
	10	3,15	2,50	4,25	3,15	6,70	4,75
	13	5,30	4,25	7,50	5,30	11,20	8,00
	16	8,00	6,30	11,20	8,00	17,00	11,80
	18	10,00	8,00	14,00	10,00	21,20	15,00
	20	12,50	10,00	17,00	12,50	26,50	19,00
	22	15,00	12,00	21,20	15,00	31,50	22,40
	26	21,20	16,95	30,00	21,20	45,00	31,50
	32	31,50	25,20	45,00	31,50	67,00	47,50
	36	40,00	31,50	56,00	40,00	85,00	60,00
	40	50,00	40,00	71,00	50,00	106,00	75,00
	45	63,00	50,40	90,00	63,00	132,00	95,00
50	80,00	64,00	112,00	80,00	160,00	118,00	
56	100,00	80,00	140,00	100,00	200,00	150,00	
10	5	1,00	0,80	1,40	1,00	2,00	1,50
	6	1,40	1,12	2,00	1,40	3,00	2,12
	7	1,90	1,50	2,65	1,90	4,00	2,80
	8	2,50	2,00	3,55	2,50	5,30	3,75
	10	4,00	3,15	5,60	4,00	8,00	6,00
	13	6,70	5,30	9,50	6,70	14,00	10,00
	16	10,00	8,00	14,00	10,00	21,20	15,00
	19	14,00	11,20	20,00	14,00	30,00	21,20
	22	19,00	15,00	26,50	19,00	40,00	28,00
	26	26,50	21,20	37,50	26,50	56,00	40,00
	32	40,00	31,50	56,00	40,00	85,00	60,00
12	7	2,36	1,90	3,35	2,36	5,00	3,55
	8	3,00	2,36	4,25	3,00	6,30	4,50
	10	5,00	4,00	7,10	5,00	10,60	7,50
	13	8,00	6,30	11,20	8,00	17,00	11,80
nierdzewne	4	0,40	0,32	0,56	0,40	0,84	0,60
	5	0,63	0,50	0,85	0,63	1,30	0,94
	6	0,90	0,72	1,25	0,90	1,85	1,35
	7	1,25	1,00	1,75	1,25	2,60	1,85
	8	1,60	1,25	2,20	1,60	3,35	2,40
	10	2,50	2,00	3,50	2,50	5,25	3,75
	13	4,25	3,40	5,96	4,25	8,90	6,35
	16	6,30	5,04	8,90	6,30	13,20	9,40

4-ciężnowe z ogniwoem wahliwym		o obwodzie zamkniętym	1-pętlowe		2-pętlowe	
						
0° do 45°	45° do 60°	-	0° do 45°	45° do 60°	0° do 45°	45° do 60°
2,8	2	1,6	1,4	1	2,1	1,5
3,15	2,24	1,80	1,60	1,12	2,36	1,70
4,00	3,00	2,50	2,12	1,50	3,15	2,24
5,60	4,00	3,15	2,80	2,00	4,25	3,00
8,50	6,30	5,00	4,25	3,15	6,70	4,75
14,00	10,60	8,50	7,50	5,30	11,20	8,00
22,40	16,00	12,50	11,20	8,00	17,00	11,80
28,00	16,00	16,00	14,00	10,00	21,20	15,00
35,00	25,00	20,00	17,00	12,50	26,50	19,00
42,00	30,00	23,60	21,20	15,00	31,50	22,40
59,36	42,40	33,50	30,00	21,20	45,00	31,50
-	-	50,00	45,00	31,50	67,00	47,50
-	-	63,00	56,00	40,00	85,00	60,00
-	-	80,00	70,00	50,00	105,00	75,00
-	-	100,80	88,20	63,00	132,00	94,50
-	-	128,00	112,00	80,00	168,00	120,00
-	-	160,00	140,00	100,00	200,00	150,00
2,80	2,00	1,60	1,40	1,00	2,00	1,50
4,00	2,80	2,24	2,00	1,40	3,00	2,12
5,30	3,75	3,00	2,65	1,90	4,00	2,80
7,10	5,00	4,00	3,55	2,50	5,30	3,75
11,20	8,00	6,30	5,60	4,00	8,00	6,00
19,00	13,20	10,60	9,50	6,70	14,00	10,00
28,00	20,00	16,00	14,00	10,00	21,20	15,00
39,20	28,00	22,40	20,00	14,00	30,00	21,20
53,20	38,00	30,00	26,50	19,00	40,00	28,00
74,20	53,00	42,50	37,50	35,50	56,00	40,00
-	-	63,00	56,00	40,00	85,00	60,00
6,70	4,75	3,75	3,35	2,36	5,00	3,55
8,50	6,00	4,75	4,25	3,00	6,30	4,50
14,00	10,00	8,00	7,10	5,00	10,60	7,50
-	-	12,50	11,20	8,00	17,00	11,80
-	-	0,64	0,56	0,40	0,84	0,60
-	-	1,00	0,85	0,63	1,30	0,94
-	-	1,40	1,25	0,90	1,85	1,35
-	-	2,00	1,75	1,25	2,60	1,85
-	-	2,50	2,20	1,60	3,35	2,40
-	-	4,00	3,50	2,50	5,25	3,75
-	-	6,80	5,96	4,25	8,90	6,35
-	-	10,00	8,90	6,30	13,20	9,40

ZAWIESIA LINOWE

- Spełniają wymagania aktualnej dyrektywy maszynowej oraz zharmonizowanej normy PN-EN 13414-1
- Zawiesia zaciskane tulejami aluminiowymi zgodnie z PN-EN 13414-3, przy użyciu prasy hydraulicznej
- Współczynnik bezpieczeństwa: 5 dla ciągnia linowego, 4 dla elementów osprzętu
- Użyte materiały: lina stalowa ocynkowana w klasie 1770 N/mm² lub 1960 N/mm² o konstrukcji 6x19+FC, 6x37+FC, WS6x36+FC (lina giętka i miękka, zapewnia wygodne użytkowanie i komfortową pracę operatorowi) komponenty w klasie 8, 10, zacisk aluminiowy cylindryczny
- Długość zawiesia wg zamówienia klienta, mierzona między punktami nośnymi „L” lub po obwodzie „Lo”
- Znakowanie: udźwig, znak CE, nazwa producenta, numer seryjny, długość robocza zawiesia
- Dokumenty: deklaracja zgodności, świadectwo jakości 2.1, instrukcja użytkowania
- Dostępne zawiesia zaciskane tulejami walcowo-stożkowymi
- Dostępne zawiesia zaplatane i zaciskane walcowo-stożkowymi tulejami stalowymi, tak zwane “Flamandzkie oko”
- Dostępne zawiesie zakończone różnego rodzaju końcówkami (socket), zalewane żywicą “Wireclock”
- Dostępne zawiesia z lin nierdzewnych i kwasoodpornych

Długość robocza zawiesia wg zamówienia klienta, mierzona między punktami nośnymi „L”

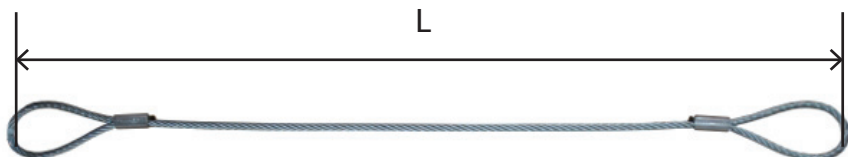

Podstawowe wymiary pętli

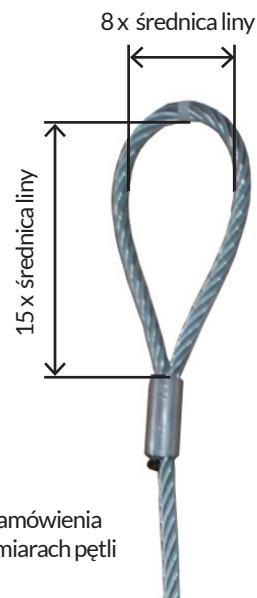

Istnieje możliwość zamówienia zawiesi o innych wymiarach pętli

ZAWIESIA LINOWE TYP F

Średnica liny mm	Udźwig [kg]*	
	układ prosty	przy pętli
8	700	560
10	1050	840
11	1300	1040
12	1550	1240
13	1800	1440
14	2120	1700
16	2700	2160
18	3400	2720
20	4350	3480
22	5200	4160
24	6300	5000
26	7200	5760
28	8400	6700
32	11000	8800
36	14000	11200
40	17000	13600
44	21000	16800
48	25000	20000



ZAWIESIA LINOWE TYP S

Średnica liny mm	Udźwig [kg]*	
	układ prosty	przy pętli
8	630	500
10	950	760
11	1150	920
12	1350	1080
13	1600	1280
14	1850	1480
16	2400	1930
18	3000	2400
20	3800	3040
22	4600	3680
24	5400	4350
26	6400	5120
28	7400	5910
32	9700	7730
36	13700	9800
40	17000	13600
44	21000	16750
48	24300	19450



* Uwaga: udźwig zawiesia może się nieco różnić w zależności od zastosowanej liny

ZAWIESIA LINOWE 1, 2, 3, 4 - CIĘGNOWE

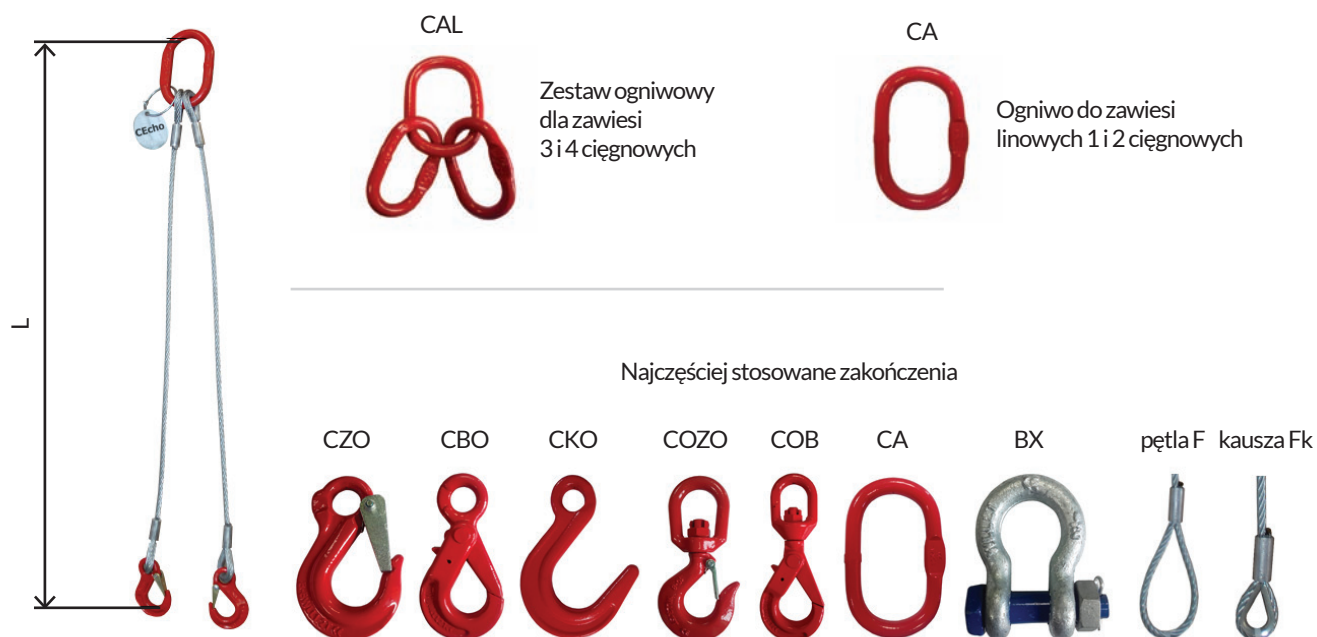

ZAWIESIA LINOWE 1, 2, 3, 4 - CIĘGNOWE

Udźwig [kg]

Średnica
liny

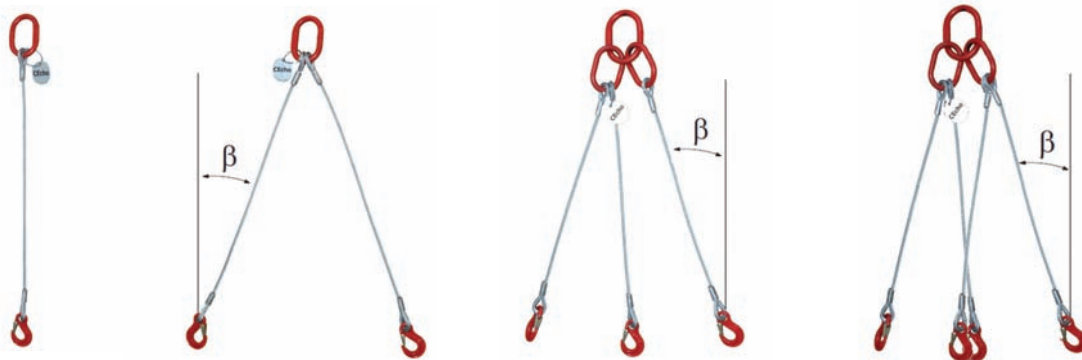

mm	układ prosty	0° do 45°	45° do 60°	0° do 45°	45° do 60°	0° do 45°	45° do 60°
8	700	950	700	1500	1050	1500	1050
10	1050	1500	1050	2250	1600	2250	1600
11	1300	1800	1300	2700	1950	2700	1950
12	1550	2120	1550	3300	2300	3300	2300
13	1800	2500	1800	3850	2700	3850	2700
14	2120	3000	2120	4350	3150	4350	3150
16	2700	3850	2700	5650	4200	5650	4200
18	3400	4800	3400	7200	5200	7200	5200
20	4350	6000	4350	9000	6500	9000	6500
22	5200	7200	5200	11000	7800	11000	7800
24	6300	8800	6300	13500	9400	13500	9400
26	7200	10000	7200	15000	11000	15000	11000
28	8400	11800	8400	18000	12500	18000	12500
32	11000	15000	11000	23500	16500	23500	16500
36	14000	19000	14000	29000	21000	29000	21000
40	17000	23500	17000	36000	26000	36000	26000
44	21000	29000	21000	44000	31500	44000	31500
48	25000	35000	25000	52000	37000	52000	37000

Długość zawiesia wg. zamówienia klienta, mierzona po obwodzie „Lo”

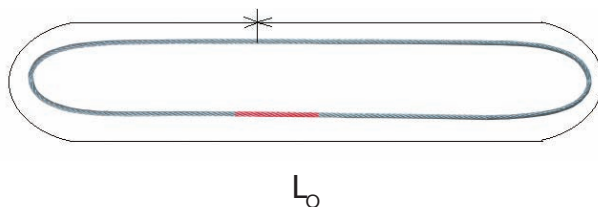

ZAWIESIA LINOWE BEZKOŃCOWE TYP FO

Średnica liny	Udźwig [kg]	
	układ prosty	przy pętli
8	1400	1100
10	2100	1700
11	2600	2120
12	3100	2500
13	3600	2900
14	4240	3300
16	5400	4350
18	6800	5650
20	8700	6900
22	10400	8400
24	12600	10000
26	14400	11800
28	16800	13500
32	22000	18000
36	28000	22500
40	34000	28000
44	42000	33500
48	50000	40000



ZAWIESIA LINOWE BEZKOŃCOWE TYP GRUMMET

Średnica liny	Udźwig [kg]	
	układ prosty	przy pętli
6	600	480
9	1400	1100
12	2500	2000
15	3900	3100
18	5600	4500
21	7700	6100
24	9800	7800
27	12500	10000
30	15400	12300
33	18600	14900
36	22000	17600
39	26000	20800
42	30200	24100
48	39400	31500
54	49800	39800
60	61500	49200
66	76300	61000
72	93300	74600
78	112600	90100
84	134400	107500
90	159000	127200
96	186600	149300
102	217500	174000
108	251800	201400
114	290500	232400
120	334300	267400
126	381000	304800
132	434000	347200
144	560800	448600
156	693800	555000

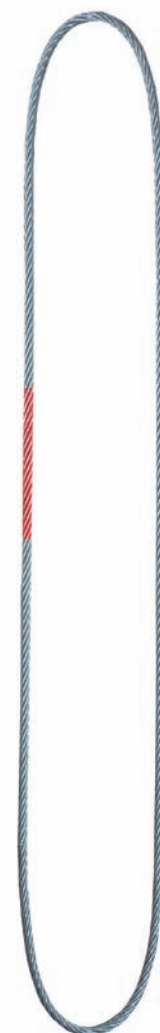

Redukcja udźwigu zawiesia przy małym promieniu zgięcia liny

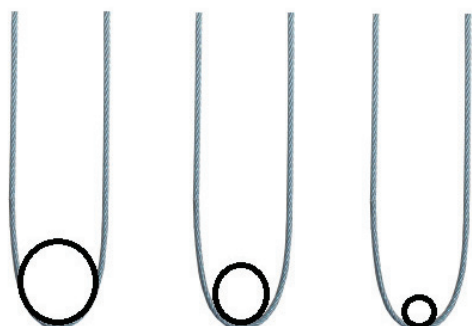

D=6 x średnica liny 100%

D=3 x średnica liny 75%

D=2 x średnica liny 65%



ZAWIESIA PASOWE

- Spełniają wymagania dyrektywy maszynowej 2006/42/WE oraz zharmonizowanej normy PN-EN 1492-1
- Zawiesia mogą być produkowane z jednej, dwóch, lub czterech warstw taśmy
- Współczynnik bezpieczeństwa: 7 dla cięgna pasowego, 4 dla elementów osprzętu
- Użyte materiały: taśma poliestrowa wysokiej jakości, bardzo mocne nici poliestrowe, tkanina ochronna na pętłach (dostępne inne materiały ochronne pętli)
- Oznakowanie barwne dla zawiesi pasowych pętlowych typu B-2, zgodnie z normą każde zawiesie ma przypisany określony kolor dzięki czemu określenie udźwigu zawiesia jest jeszcze łatwiejsze
- Maksymalna temperatura pracy to 100° C
- Zawiesia wykazują dużą odporność na: oleje, wilgoć, opary benzyn
- Zalety: duża nośność przy jednocześnie niskiej wadze zawiesia, taśma nie uszkadza delikatnych ładunków, zawiesie nie rani dłoni operatora, zachowuje wysoką odporność na ścieranie, nie rdzewieje i jest wygodne w magazynowaniu
- Długość zawiesia wg zamówienia klienta, mierzona między punktami nośnymi „L”
- Znakowanie: udźwig, znak CE, nazwa/symbol producenta, numer seryjny, długość robocza zawiesia, data produkcji
- Dokumenty: deklaracja zgodności, świadectwo jakości 2.1, instrukcja użytkowania

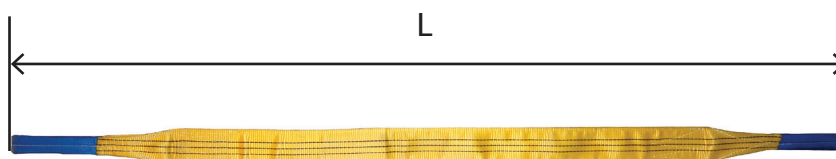
Długość zawiesia wg. zamówienia klienta, mierzona między punktami nośnymi „L”

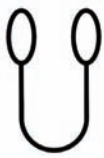
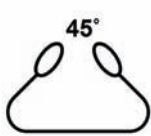
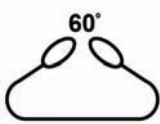

ZAWIESIA PASOWE PĘTLOWE JEDNO, DWU I CZTEROWARSTWOWE

Barwa zawiesia	Udźwig [kg]					Typ zawiesia		
						B-1	B-2 (standard)	B-4
	100% (układ podstawowy)	80%	200%	140%	100%	Szerokość zawiesia w [mm]		
fioletowa	500	400	800	700	500	30	-	-
	1 000	800	2 000	1 400	1 000	60	30	-
zielona	2 000	1 600	4 000	2 800	2 000	120	60	30
żółta	3 000	2 400	6 000	4 200	3 000	180	90	-
szara	4 000	3 200	8 000	5 600	4 000	240	120	60
czerwona	5 000	4 000	10 000	7 000	5 000	300	150	-
brązowa	6 000	4 800	12 000	8 400	6 000	-	180	90
niebieska	8 000	6 400	16 000	11 200	8 000	-	240	120
pomarańczowa	10 000	8 000	20 000	14 000	10 000	-	300	150
	12 000	9 600	24 000	16 800	12 000	-	-	180
	16 000	12 800	32 000	22 400	16 000	-	-	240
	20 000	16 000	40 000	28 000	20 000	-	-	300

SZEROKOŚĆ I DŁUGOŚĆ PĘTLI

szerokość zawiesia w [mm]	szerokość pętli w [mm]			standardowa długość pętli w [mm]
	pętla standard „A” (taka pętla jest szyta domyślnie)	pętla wąska „B”	pętla płaska „C”	
30	30	-	30	280
60	30	25	60	300
90	45	35	90	400
120	60	45	120	400
150	75	55	150	480
180	90	65	180	580
240	120	85	240	610
300	150	105	300	840



pętla „A”
składana
na 1/2
(standard)



pętla „B”
wąska
składana
na 1/3



pętla „C”
płaska



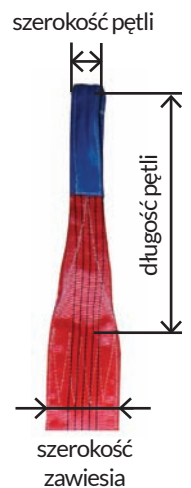

pętla „D”
składana
na 1/2
z pełnym
obszyciem

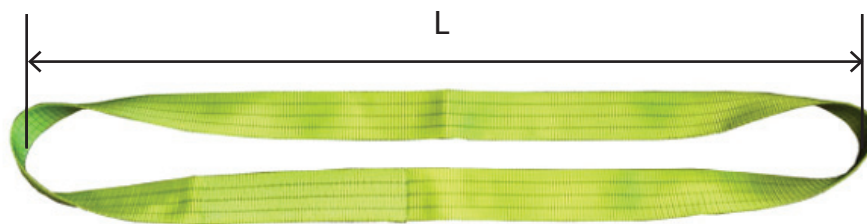

ZAWIESIA PASOWE O OBWODZIE ZAMKNIĘTYM

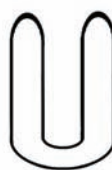
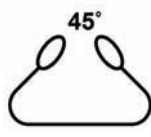
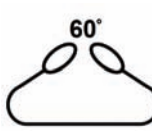

Barwa zawiesia	Udźwig [kg]					Typ zawiesia	
						A-2 (standard)	A-4
	100% (układ podstawowy)	80%	200%	140%	100%	Szerokość zawiesia w [mm]	
fioletowa	1 000	800	2 000	1 400	1 000	30	-
zielona	2 000	1 600	4 000	2 800	2 000	60	30
żółta	3 000	2 400	6 000	4 200	3 000	90	-
szara	4 000	3 200	8 000	5 600	4 000	120	60
czerwona	5 000	4 000	10 000	7 000	5 000	150	-
brązowa	6 000	4 800	12 000	8 400	6 000	180	90
niebieska	8 000	6 400	16 000	11 200	8 000	240	120
pomarańczowa	10 000	8 000	20 000	14 000	10 000	300	150
	12 000	9 600	24 000	16 800	12 000	-	180
	16 000	12 800	32 000	22 400	16 000	-	240
	20 000	16 000	40 000	28 000	20 000	-	300

ZAWIESIE PASOWE BEZKOŃCOWE TYP A-2 JEDNORAZOWE - WSPÓŁCZYNNIK BEZPIECZEŃSTWA 5:1

- Zawiesie jednorazowe przeznaczone są do wykonania jednorazowej operacji załadunku, transportu i rozładunku towaru. Po tym procesie zgodnie z normą DIN 60005 muszą zostać utylizowane
- Najczęściej zawiesia jednorazowe zakładane są w trakcie produkcji elementów, następnie po dostarczeniu ładunku na budowę i zamontowaniu go, zawiesie zostaje odcięte
- Udźwig zawiesia i szerokość taśmy dobieramy indywidualnie, pozwala to optymalizować koszt zawiesia. Najczęściej stosowane taśmy o szerokości 25mm, 35mm, 40mm, 50mm



OSŁONY DO ZAWIESI PASOWYCH

OSŁONY CHRONIĄCE ZAWIESIE PRZED PRZETARCIEM

OSŁONY CHRONIĄCE ZAWIESIE PRZED PRZECIĘCIEM



Ostona PES



Ostona PES na rzep



Ostona PESSOFT



Ostona poliuretanowa nasuwana



Ostona poliuretanowa zalewana na zawieszce



Ostona kątowna poliuretanowa z magnesami

ZAWIESIA PASOWE 1, 2, 3, 4 - CIĘGNOWE

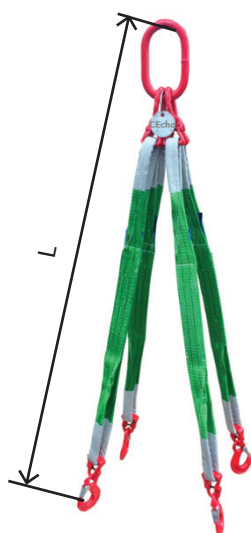

Najczęściej stosowane zakończenia



szerokość zawiesia w [mm]	Udźwig [kg]							
	układ prosty	0° do 45°	45° do 60°	0° do 45°	45° do 60°	0° do 45°	45° do 60°	
30	1 000	1400	1000	2 100	1 500	2 100	1 500	
60	2 000	2800	2000	4 200	3 000	4 200	3 000	
90	3 000	4200	3000	6 300	4 500	6 300	4 500	
120	4 000	5600	4000	8 400	6 000	8 400	6 000	
150	5 000	7 000	5 000	10 500	7 500	10 500	7 500	
180	6 000	8 400	6 000	12 600	9 000	12 600	9 000	
240	8 000	11 200	8 000	16 800	12 000	16 800	12 000	
300	10 000	14 000	10 000	21 000	15 000	21 000	15 000	

ZAWIESIA WĘŻOWE

- Spełniają wymagania dyrektywy maszynowej 2006/42/WE oraz zharmonizowanej normy PN-EN 1492-2
- Zawiesia są produkowane z przędzy poliestrowej umieszczonej w rękawie ochronnym
- Współczynnik bezpieczeństwa: 7 dla ciągu wężowego, 4 dla elementów osprzętu
- Użyte materiały: przędza poliestrowa wysokiej jakości, rękaw ochronny
- Oznakowanie barwne zawiesi, zgodnie z normą każdy udźwig zawiesia ma przypisany kolor, dzięki czemu określenie udźwigu zawiesia jest jeszcze łatwiejsze
- Maksymalna temperatura pracy to 100° C
- Zawiesia wykazują dużą odporność na: oleje, wilgoć, opary benzyn
- Zalety: duża nośność przy jednocześnie niskiej wadze zawiesia, zawiesie nie uszkadza delikatnych ładunków, zawiesie nie rani dłoni operatora, zachowuje wysoką odporność na tarcie, nie rdzewieje i jest wygodne w składowaniu
- Znakowanie: udźwig, znak CE, nazwa producenta, numer seryjny, długość robocza zawiesia, data produkcji
- Dokumenty: deklaracja zgodności, świadectwo jakości 2.1, instrukcja użytkowania

Długość zawiesia wg. zamówienia klienta, mierzona między punktami nośnymi „L”

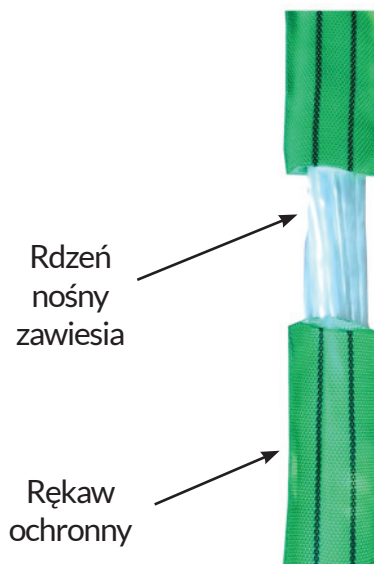
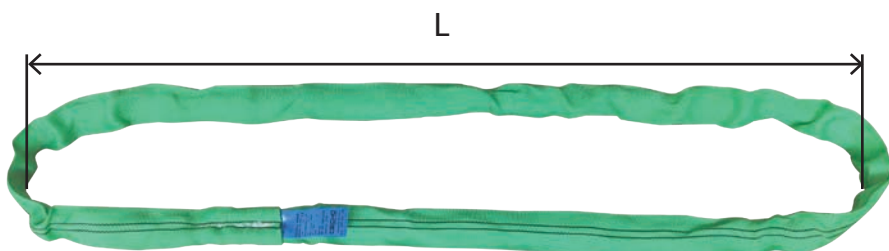

ZAWIESIA WĘŻOWE TYP ZW

Barwa zawiesia	udźwig [kg]				
	100% (układ podstawowy)	80%	200%	45°	60°
fioletowa	1 000	800	2 000	1 400	1 000
zielona	2 000	1 600	4 000	2 800	2 000
żółta	3 000	2 400	6 000	4 200	3 000
szara	4 000	3 200	8 000	5 600	4 000
czerwona	5 000	4 000	10 000	7 000	5 000
brązowa	6 000	4 800	12 000	8 400	6 000
niebieska	8 000	6 400	16 000	11 200	8 000
pomarańczowa	10 000	8 000	20 000	14 000	10 000
	12 000	9 600	24 000	16 800	12 000
	15 000	12 000	30 000	21 000	15 000
	20 000	16 000	40 000	28 000	20 000
	25 000	20 000	50 000	35 000	25 000
	30 000	24 000	60 000	42 000	30 000
	40 000	32 000	80 000	56 000	40 000
	50 000	40 000	100 000	70 000	50 000
	60 000	48 000	120 000	84 000	60 000
	80 000	64 000	160 000	112 000	80 000
100 000	80 000	200 000	140 000	100 000	
120 000	96 000	240 000	168 000	120 000	
150 000	120 000	300 000	210 000	150 000	

ZAWIESIA WĘŻOWE 1, 2, 3, 4 - CIĘGNOWE

układ prosty	Udźwig [kg]					
	0° do 45°	45° do 60°	0° do 45°	45° do 60°	0° do 45°	45° do 60°
1 000	1400	1000	2 100	1 500	2 100	1 500
2 000	2800	2000	4 200	3 000	4 200	3 000
3 000	4200	3000	6 300	4 500	6 300	4 500
4 000	5600	4000	8 400	6 000	8 400	6 000
5 000	7 000	5 000	10 500	7 500	10 500	7 500
6 000	8 400	6 000	12 600	9 000	12 600	9 000
8 000	11 200	8 000	16 800	12 000	16 800	12 000
10 000	14 000	10 000	21 000	15 000	21 000	15 000

Najczęściej stosowane zakończenia



ODCIĄGI ŁAŃCUCHOWE

- Spełniają wymagania normy PN-EN 12195-3
- Standardowa długość 3,5m (lub wykonanie wg. zamówienia klienta)
- Współczynnik bezpieczeństwa: 2
- Łańcuch zabezpieczony przed korozją, komponenty malowane proszkowo
- Znakowanie: zdolność mocowania LC, nazwa producenta, numer seryjny, długość odciągu, rok produkcji
- Dokumenty: świadectwo jakości 2.1, instrukcja użytkowania

ODCIĄG ŁAŃCUCHOWY TYP ZRS

ODCIĄG ŁAŃCUCHOWY TYP SWRLS



Długość standardowa L = 3500 mm

Klasa łańcucha	Rozmiar łańcucha	Zdolność mocowania LC* [kN]	Nominalna siła napięcia STF* [daN]	Zakres napinania [mm]	Szerokość gardzieli haka [mm]	Waga odciągu typu ZRS o długości 3,5 m	
8	Standard	6	22,4	560	120	20	6,5
		8	40	1000	145	27	9,5
		10	63	1575	215	31	14
		13	106	1590	280	39	25
		16	200	3000	250	46	39
10		7	38	950	145	27	8,8
		8	50	1250	145	26	9,5
		10	80	2000	145	31	14
		13	134	2010	290	39	25
12		8	60	1500	145	26	9,5
		10	100	2500	145	31	14
		13	160	2400	290	39	25

*LC - Zdolność Mocowania - jest to najwyższa siła, dla której odciąg/pas może zostać użyty przy mocowaniu w układzie prostym, tj. od punktu do punktu. W uproszczeniu 10 kN = 1 tona.

*STF Nominalna Siła Napięcia - jest to siła powstająca w łańcuchu w wyniku zadziałania dźwigni

PASY MOCUJĄCE/ ŚRODKI DO MOCOWANIA ŁADUNKU

- Spełniają wymagania normy PN-EN 12195-2
- Długość wykonania wg. zamówienia klienta
- Współczynnik bezpieczeństwa: 2 dla elementów stalowych, 3 dla taśmy poliestrowej
- Haki i napinacz zabezpieczono przed korozją poprzez ocynkowanie
- Taśma użyta do produkcji pasów transportowych została poddana impregnacji co dodatkowo zwiększa wytrzymałość pasa na ścieranie.
- Pasy mocujące „CPM” wykazują dużą odporność na butwienie, nie przyjmują wilgoci i nie rdzewieją, zapewniając użytkownikowi komfort ich stosowania przez długi czas
- Znakowanie: zdolność mocowania LC, STF, nazwa producenta, numer seryjny, długość pasa, rok produkcji
- Dokumenty: Świadectwo jakości 2.1, instrukcja użytkowania

PAS MOCUJĄCY 2-CZĘŚCIOWY

Typ	Zdolność mocowania LC [daN]	Szerokość taśmy [mm]	Długość pasa [mm]	Zakończenie pasa
CPM2-25	500	25		
CPM2-35	1000	35		
CPM2-40	2000	50	według zamówienia	standardowo hak profilowy dwupalczasty – lub według zamówienia klienta
CPM2-50	2500	50		
CPM2-75	5000	75		



PAS MOCUJĄCY 1-CZĘŚCIOWY



Typ	Zdolność mocowania LC [daN]	Szerokość taśmy [mm]	Długość pasa [mm]
CPM1-25	1 000	25	według zamówienia
CPM1-35	2 000	35	
CPM1-40	4 000	50	
CPM1-50	5 000	50	
CPM1-75	10 000	75	

PAS MOCUJĄCY 2-CZĘŚCIOWY DO LAWET

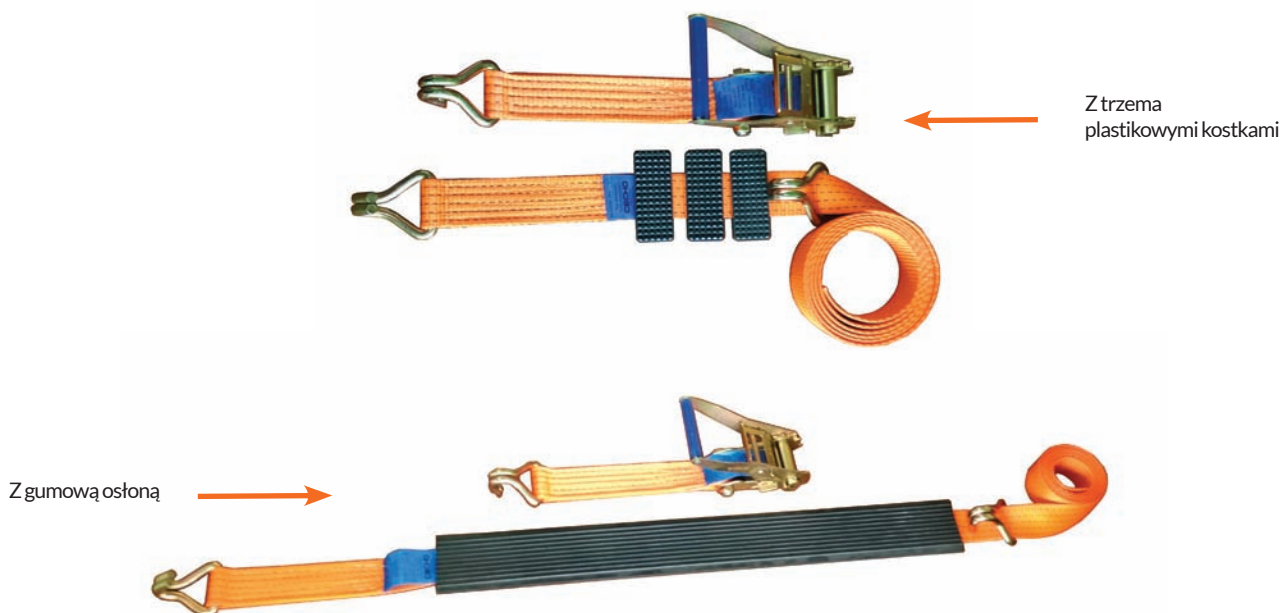

Typ	Zdolność mocowania LC [daN]	Szerokość taśmy [mm]	Długość pasa	Zakończenie pasa
CPM2-LW	2 000	50	standardowo 3 m, lub na zamówienie klienta	standardowo 3 haki profilowe dwupalczaste, lub według zamówienia klienta

PAS MOCUJĄCY 2-CZĘŚCIOWY Z DŁUGĄ RĄCZKĄ

Typ	Zdolność mocowania LC [daN]	Szerokość taśmy [mm]	Długość pasa [mm]	Zakończenie pasa
CPM2-Long	2500	50	według zamówienia	standardowo hak profilowy dwupalczasty - lub według zamówienia klienta



Zastosowanie dłuższej dźwigni pozwala na uzyskanie większego momentu siły na mechanizmie napinacza i mocniejsze napięcie taśmy

Kierunek działania siły na dźwigni napinacza

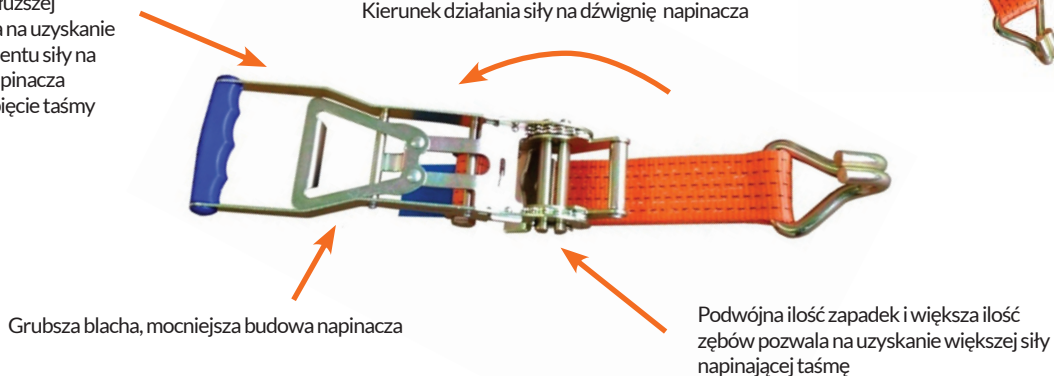

Grubsza blacha, mocniejsza budowa napinacza

Podwójna ilość zapadek i większa ilość zębów pozwala na uzyskanie większej siły napinającej taśmę

BELKA NABURTOWA ALUMINIOWA

Zakres mocowania 2400 - 2700mm



DRAŻEK ROZPOROWY

Zakres mocowania 2400 - 2700mm



OSŁONA KĄTOWA DUŻA XL DO PASÓW MOCUJĄCYCH

- Pasuje do pasów mocujących z taśmy 35mm, 50mm szerokości
- Długość ramion 160mm x 200mm, szerokość 150mm



OSŁONA KĄTOWA MAŁA X DO PASÓW MOCUJĄCYCH

- Pasuje do pasów mocujących z taśmy 35mm, 50mm szerokości
- Długość ramion 90mm x 90mm, szerokość 130mm
- Elastyczna osłona dostosowuje kształt do ładunku



AKCESORIA ZAWIESIOWE KLASA 8

- Spełniają wymagania dyrektywy maszynowej 2006/42/WE i norm grupy PN-EN 1677
- Współczynnik bezpieczeństwa: 4
- Użyte materiały: stal w klasie 8 (wytrzymałość na rozciąganie 800 N/mm²)
- Łańcuch zabezpieczony przed korozją, komponenty malowane proszkowo
- Znakowanie: udźwigny, znak CE, rozmiar, klasa wytrzymałości
- Dokumenty: deklaracja zgodności, świadectwo jakości 2.1, instrukcja użytkowania

OGNIWO GŁÓWNE CA

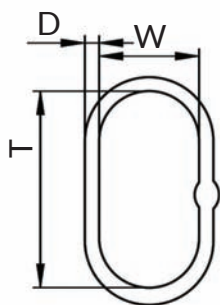

Typ	DOR przy kącie 0-45°[t]	D [mm]	W [mm]	T [mm]	Masa [kg/szt.]
CA 14	1,6	14	60	110	0,34
CA 16	2,12	16	60	110	0,53
CA 18	3,15	18	75	135	0,83
CA 22	5,3	22	90	160	1,5
CA 26	8,0	26	100	180	2,32
CA 32	11,2	32	110	200	3,95
CA 36	14,0	36	140	260	6,34
CA 40	17,0	40	160	300	8,96
CA 45	21,2	45	180	340	12,8
CA 50	31,5	50	190	350	16,55
CA 56	45,0	56	200	400	23,28
CA 63	56,0	63	220	430	32

ZESTAW OGNIWOWY DO ZAWIESI LINOWYCH I PASOWYCH CAL

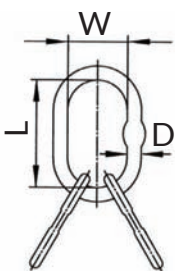

Typ	Rozmiar	DOR [t] 4:1	DOR [t] 5:1	D [mm]	W [mm]	L [mm]	Masa [kg/szt.]
CAL240	14	2.4	2	14	60	100	0.82
CAL320	17	3.2	2.5	18	90	160	1.61
CAL5000	20	5	4	20	90	160	1.95
CAL8000	22	8	6.4	22	100	180	3.16
CAL1200	28	12	9.6	28	140	270	6.75
CAL1740	32	17.4	13.9	32	140	270	9.31

ZESTAW OGNIWOWY DO ZAWIESI ŁAŃCUCHOWYCH I WĘŻOWYCH CAZ

Typ	DOR przy kącie 0-45°[t]	D [mm]	W [mm]	T [mm]	G [mm]	B [mm]	A [mm]	S [mm]	Masa [kg/szt.]
CAZ 18	2,36	18	75	135	14	24	62	8	1,18
CAZ 19	3,15	19	75	135	14	38	60	8	1,35
CAZ 22	4,25	22	90	160	16	34	70	9	2,2
CAZ 26	6,7	26	100	180	18	40	85	12	3,1
CAZ 33	11,2	33	110	200	22	50	115	14	6,0
CAZ 36	17,0	36	140	260	26	65	140	16	9,6
CAZ 45	21,2	45	180	340	32	100	180	19	19,85
CAZ 50	26,5	50	190	350	32	100	180	20	23,35
CAZ 50	31,5	50	190	350	36	100	180	--	25,25
CAZ 50	45,0	50	190	350	40	100	180	--	26,40
CAZ 63	67,0	63	220	430	50	100	180	33	47,48

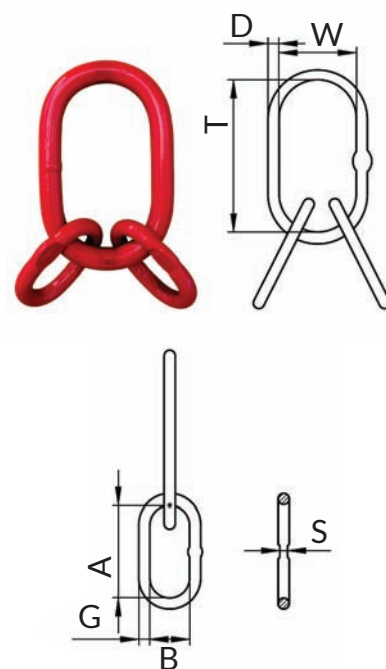

HAK SKRACAJĄCY Z UCHEM CSO

Typ	Rozmiar	DOR [t]	E [mm]	G [mm]	Masa [kg/szt.]
CSO 112	6	1.12	51	8	0.14
CSO 200	7/8	2	60.5	10.8	0.245
CSO 315	10	3.15	79.5	13	0.65
CSO 530	13	5.3	99.7	16.5	1.39
CSO 800	16	8	104	19.2	2.2
CSO 1250	20	12.5	140	24	4.6
CSO 1500	22	15	165	28	8.2
CSO 2120	26	21.2	188.5	30	9.8
CSO 3150	32	31.5	228	38	19.4

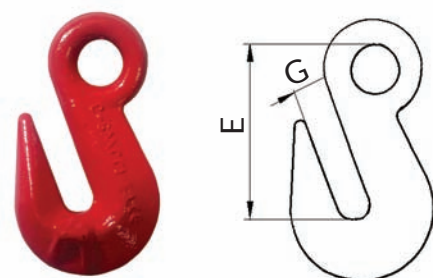

HAK SKRACAJĄCY WIDŁKOWY CSW

Typ	DOR [t]	W [mm]	D [mm]	E [mm]	Masa [kg/szt.]
CSW 5-6	1.4	47,4	7,4	45	0,19
CSW 7	1,9	58	9	61	0,38
CSW 8	2,5	58	10	60,5	0,38
CSW 10	4	76	12,5	76	0,85
CSW 13	6,7	101	16	104	1,9
CSW 16	10	122	20	107	3,6
CSW 19	16	150	24	141	6,15
CSW 22	19	165	27	158	9

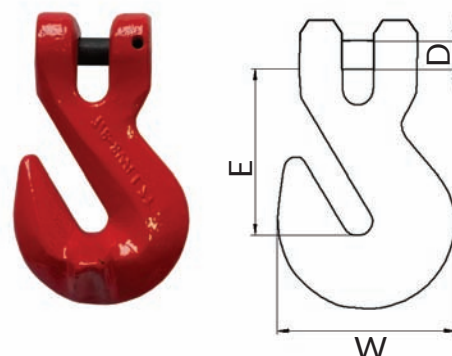

ZŁĄCZKA ŁAŃCUCHOWA CMG

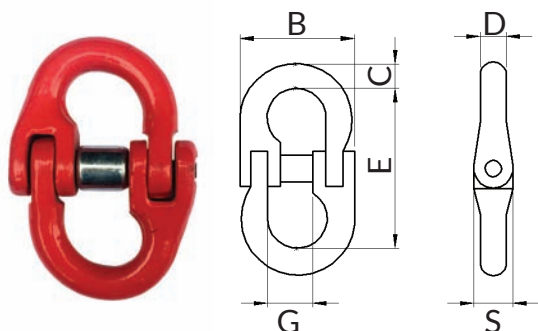

Typ	Rozmiar	DOR [t]	E [mm]	G [mm]	Masa [kg/szt.]
CMG 112	6	1.12	42	16.2	0.08
CMG 200	7/8	2	58	20.5	0.16
CMG 315	10	3.15	68	28	0.3
CMG 530	13	5.3	90	30	0.6
CMG 800	16	8	101.9	36.3	1.1
CMG 1250	18/20	12.5	121	44	2
CMG 1500	22	15	141.5	51	3.2
CMG 2120	26	21.2	161	58	4.8
CMG 3150	32	31.5	197	67.5	9

ZŁĄCZKA DO ZAWIESI PASOWYCH I WĘŻOWYCH CMW

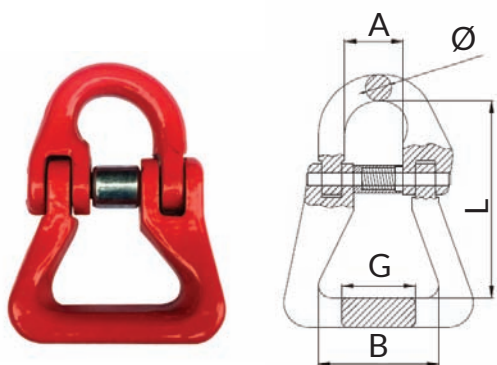

KOD	Rozmiar	DOR [t]	L [mm]	A [mm]	B [mm]	G [mm]	Masa [kg/szt.]
CMW 112	6	1.12	54	12	37	18	0.18
CMW 200	7/8	2	64	15	36	24	0.29
CMW 315	10	3.15	82	21	39	30	0.51
CMW 530	13	5.3	95	22	52	35	1.03
CMW 800	16	8	115	26	63	45	1.9
CMW 1250	18/20	12.5	135	32	77	52	3.06
CMW 1500	22	15	168	37	124	70	6.6
CMW 2120	26	21.2	204	41	150	86	10.45
CMW 3150	32	31.5	275	44	160	92	18.65

ŁAŃCUCH ZAWIESIOWY KLASA 8

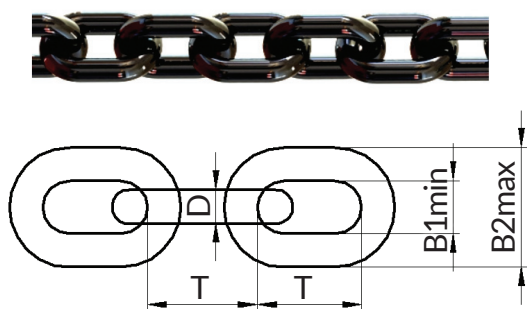

Rozmiar średnica D [mm]	DOR [t]	MBL [kN]	T [mm]	B1min [mm]	B2max [mm]	Masa [kg/m]
6	1,12	45,2	18	7,8	22,2	0,8
8	2,0	80,4	24	10,4	29,6	1,4
10	3,15	126	30	13	37	2,2
13	5,3	212	39	16,9	48,1	3,8
16	8,0	322	48	20,8	59,2	5,7
18	10,0	400	54	23,4	66,6	7,3
20	12,5	500	60	26,0	74,0	9,0
22	15,0	600	66	28,6	81,4	10,9
26	21,2	848	78	33,8	96,2	15,2
32	31,5	1260	96	41,6	118,0	23,0

HAK WIDEŁKOWY CZW

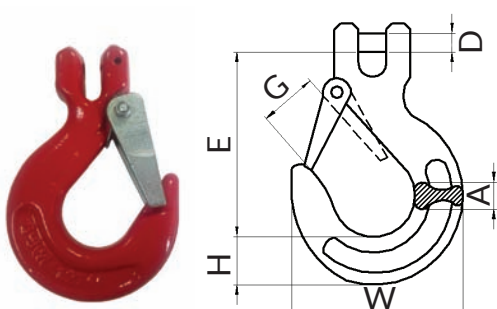

Typ	Rozmiar	DOR [t]	E [mm]	G [mm]	H [mm]	Masa [kg/szt.]
CZW 112	6	1.12	76	26	23	0.32
CZW 200	7/8	2	85.5	29	32.5	0.52
CZW 315	10	3.15	104	39	35	1.05
CZW 530	13	5.3	128	47	42.5	2
CZW 800	16	8	150	55	54	3.7
CZW 1250	20	12.5	180	61	58	6
CZW 1500	22	15	213	72	62	10.4

HAK Z UCHEM CZO

Typ	DOR [t]	MBL [kN]	E [mm]	W [mm]	B [mm]	D [mm]	A [mm]	G [mm]	H [mm]	Masa [kg]
CZO 6-8	1,12	43,9	80	68	20	9	18	20	22	0,35
CZO 8-8	2,0	78,5	95	82	25	11,5	18	22	26	0,45
CZO 10-8	3,15	124,0	117	104	33	16,5	21,5	33	36	0,90
CZO 13-8	5,3	208,0	152	132	42	20,5	28	34	47	2,10
CZO 16-8	8,0	314,0	184	153	50	23	33	48	48	3,10

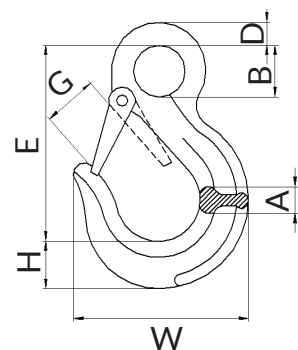

HAK BEZPIECZNY WIDEŁKOWY CBW

Typ	Rozmiar	DOR [t]	H [mm]	E [mm]	Masa [kg/szt.]
CBW 112	6	1.12	19.5	95.5	0.5
CBW 200	7/8	2	24	121	0.8
CBW 315	10	3.15	28.5	146	1.5
CBW 530	13	5.3	40	182	2.8
CBW 800	16	8	50.5	218	5.6
CBW 1250	20	12.5	55	240	7.5
CBW 1500	22	15	67	276.5	11.5
CBW 21210	26	21,2	75	310.5	18.5

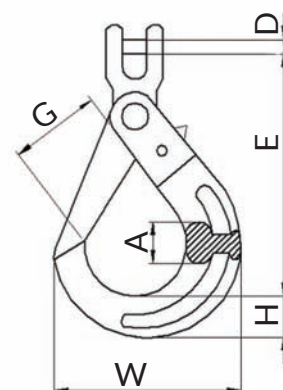

HAK BEZPIECZNY Z UCHEM CBO

Typ	Rozmiar	DOR [kg]	E [mm]	H [mm]	B [mm]	D [mm]
CBO 112	6	1.12	110.5	19.5	22	10
CBO 200	7/8	2	136	24	25	12
CBO 315	10	3.15	171	28.5	32	15
CBO 530	13	5.3	208.5	40	40.5	19.5
CBO 800	16	8	257.5	50.5	56	22
CBO 1250	20	12.5	275	55	64.5	27
CBO 1500	22	15	320	67	70	30
CBO 21210	26	21,2	363	75	80	34
CBO 31500	32	31,5	472	97	105	45

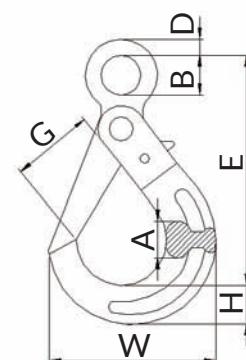

HAK OBROTOWY NA ŁOŻYSKU KULKOWYM COZK

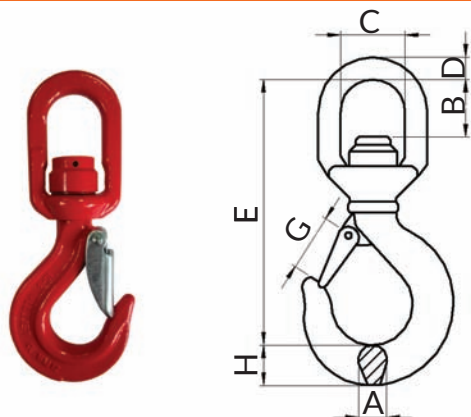

Typ	Rozmiar	DOR [t]	G [mm]	D [mm]	E [mm]	H [mm]	A [mm]	Masa [kg/szt.]
COZK 200	7/8	2	25	13	167	25	20	0,93
COZK 315	10	3.15	33	19	202	30	23	1,65
COZK 530	13	5.3	37	20	241	40	32	3,01
COZK 800	16	8	44	22	284	46	38	5,55
COZK 1250	20	12.5	51	29	354	51	51	10,1

*Hak umożliwia obracanie ładunkiem pod obciążeniem

HAK OBROTOWY NA ŁOŻYSKU ŚLIZGOWYM COZO

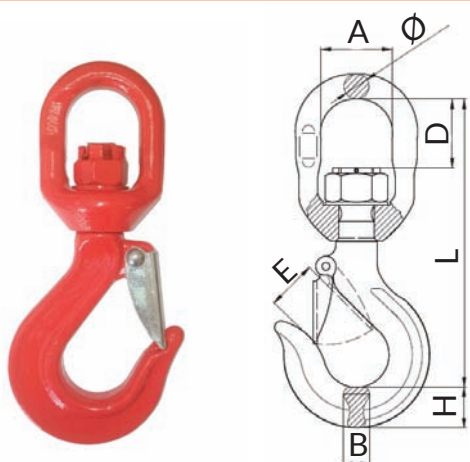

Typ	Rozmiar	DOR [t]	A [mm]	E [mm]	D [mm]	φ [mm]	L [mm]	B [mm]	H [mm]	Masa [kg/szt.]
COZO 112	6	1.12	31	21	25	10	110	16	21	0,37
COZO 200	7/8	2	35	25	26	13	153	20	25	0,87
COZO 15	10	3.15	41	33	32	19	186	23	30	1,57
COZO 530	13	5.3	46	37	41	20	232	32	40	3,19
COZO 800	16	8	59	44	50	22	275	38	46	5,25
COZO 1250	20	12.5	67	51	53	29	305	51	51	7,3
COZO 1500	22	15	77	57	66	34	326	56	67	12,6
COZO 21200	26	21,2	103	70	110	42	418	70	75	23,5

HAK OBROTOWY BEZPIECZNY NA ŁOŻYSKU KULKOWYM COBK

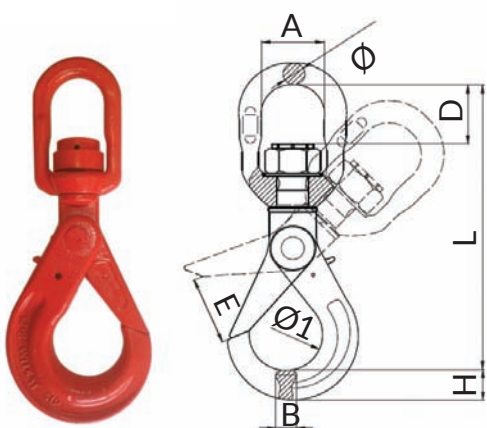

Typ	Rozmiar	DOR [t]	G [mm]	D [mm]	H [mm]	A [mm]	Masa [kg/szt.]
COBK 200	7/8	2,0	38	13	21	16	1,20
COBK 315	10	3.15	47	19	31	26	2,12
COBK 530	13	5.3	51	20	42	32	3,7
COBK 800	16	8	58	22	50	38	7,45
COBK 1250	20	12.5	70	29	57	50	12,1
COBK 1500	22	15	72	34	69	53	17,8
COBK 2120	26	21,2	92	42	75	60	29,9

*Hak umożliwia obracanie ładunkiem pod obciążeniem

HAK OBROTOWY BEZPIECZNY NA ŁOŻYSKU ŚLIZGOWYM COB

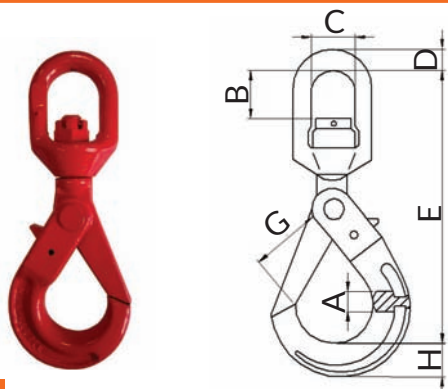

Typ	Rozmiar	DOR [t]	E [mm]	∅ [mm]	L [mm]	A [mm]	D [mm]	Masa [kg/szt.]
COB 112	6	1.12	26	10	153	32	20	0,74
COB 200	7/8	2	38	13	180	35	25	1,15
COB 315	10	3.15	47	19	215	41	33	2,0
COB 530	13	5.3	51	20	250	49	41	3,83
COB 800	16	8	58	22	331	69	54	7,20

HAK KONTENEROWY Z UCHEM CKO

Typ	Rozmiar	DOR [t]	E [mm]	H [mm]	B [mm]	G [mm]	A [mm]	Masa [kg/szt.]
CKO 200	7/8	2	120	31	18	63,5	25	1,09
CKO 315	10	3.15	146	33	22	76	32	1,95
CKO 530	13	5.3	175	44,5	27	89	38	3,22
CKO 800	16	8	205	51,5	32	101	46	5,26
CKO 1250	20	12.5	235	65	38	114	56	9,07
CKO 1500	22	15	264	68,5	45	127	57	11,79

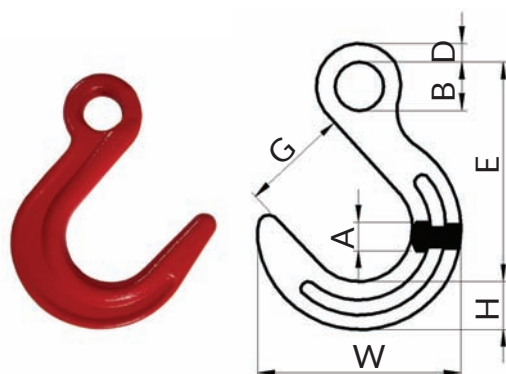

HAK SORTOWNICZY SHAK

Typ	DOR [kg]	MBL [kN]	E [mm]	B [mm]	D [mm]	A [mm]	G [mm]	H [mm]	Masa [kg/szt.]
SHAK 8-8	2000	78,5	195	34	19	38	70	51	3,15

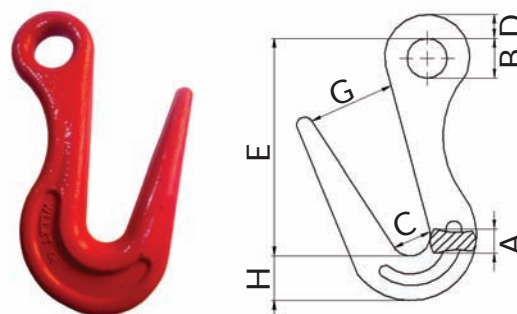

ZŁĄCZKA ŁAŃCUCHOWA OMEGA FRC

Typ	DOR [t]	L [mm]	A [mm]	Ø [mm]	B [mm]	Masa [kg/szt.]
FRC 112	1,12	26	7	19,5	41	0,08
FRC 200	2,0	34	9	22	52	0,17
FRC 315	3,15	45	12	31	62	0,32
FRC 530	5,3	53	14	39,4	81	0,70
FRC 800	8,0	63	18	48	99	1,16

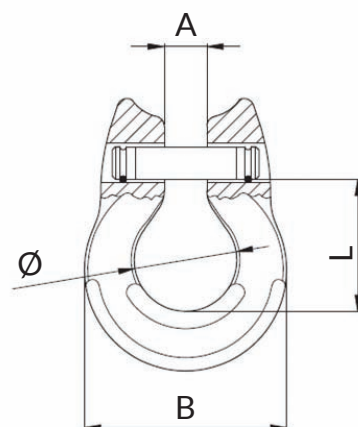

ZŁĄCZKA ŁAŃCUCHOWA UNILOCK U

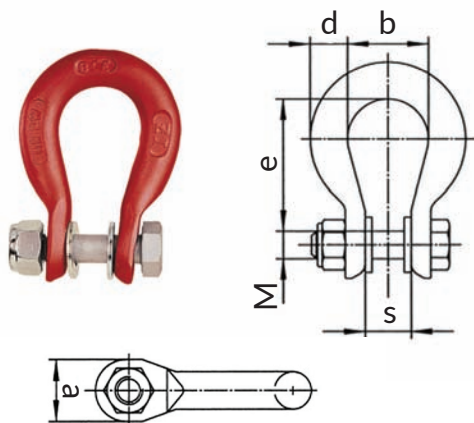

Typ	DOR [kg]	e [mm]	b [mm]	d [mm]	s [mm]	a [mm]	M [mm]	Masa [kg/szt.]
U 5/6	1.120	34	21	9	11	16	7	0,07
U 7	1.500	49	28	13	16	22	8	0,20
U 8	2.000	48	28	13	16	22	10	0,22
U 10	3.150	60	35	16	20	27	12	0,38
U 13	5.300	72	39	18	24	34	16	0,67
U 16	8.000	80	47	23	32	44	20	1,21
U 19/20	12.500	96	56	26	36	52	24	1,97
U 26	21.200	132	77	33	49	66	30	4,06

HAK SM

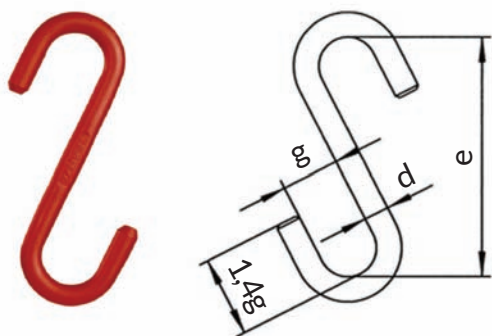

Typ	Dopuszczalne obciążenie robocze [kg]	e [mm]	g [mm]	d [mm]	Masa [kg/szt.]
SM 5	800	180	42	16	0,60
SM 7/8	2 000	220	23	23	1,50
SM 10	3 150	280	28	31	2,90
SM 13	5 300	400	90	40	8,20
SM 16	8 000	500	120	50	16,00
SM 19	11 200	550	130	60	26,00
SM 22	15 000	750	175	80	64,50

KRĘTLIK DF

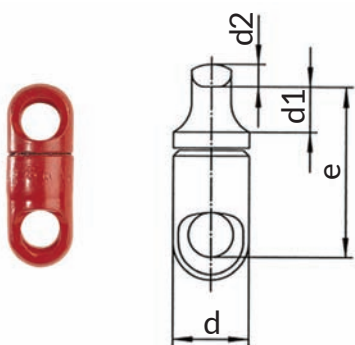

Typ	DOR [kg]	e [mm]	d [mm]	d1 [mm]	d2 [mm]	Masa [kg/szt.]
DF 5/6	1120	44	22	12	7	0,10
DF 7/8	2000	66	27	16	8	0,20
DF 10	3150	74	32	20	10	0,30
DF 13	5300	92	40	25	13	0,60

HAK DO PRZYSPAWANIA CRB

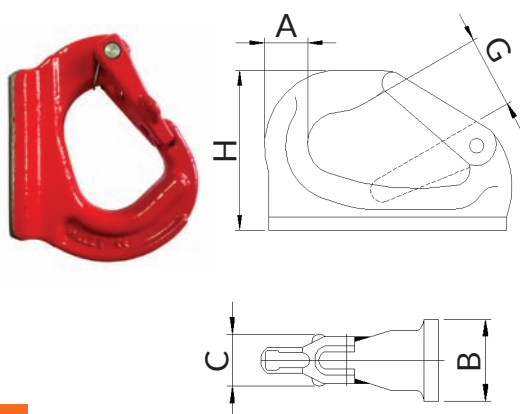

DOR [kg]	CRB [kN]	A [mm]	B [mm]	C [mm]	G [mm]	L [mm]	H [mm]	Masa [kg/szt.]
2000	78,5	23	34	36,5	26	81	91	0,80
3000	117,7	31	36	38	30	115	105	1,25
5000	196,1	45	43,5	48	36	159	131	2,55
8000	314,0	50	51	49	32	165	135	3,25
10000	392,3	54	55	48	45	202	168	5,60

GNIAZDO KONTENEROWE CNA

Typ	DOR [kg]	MBL [kN]	E [mm]	B [mm]	C [mm]	D [mm]	A [mm]	G [mm]	H [mm]	Masa [kg/szt.]
CNA 13-8	5300	208,0	145	18	19	16	71	50	19	2,10

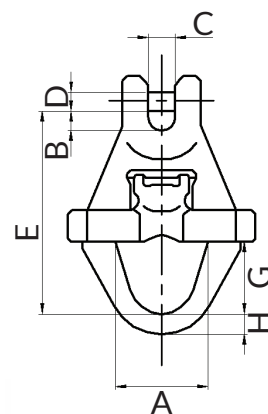

OGNIWO PŁASKIE DO ZAWIESI PASOWYCH ED

Typ	Szerokość pasa [mm]	DOR [mm]	e [mm]	b [mm]	d1 [mm]	Masa [kg/szt.]
ED 40	30	1,0	80	40	13	0,3
ED 75	60	2,0	125	75	16	0,7
ED 105	90	3,0	165	105	20	1,5
ED 135	120	4,0	210	135	23	2,5
ED 165	150	5,0	245	165	26	3,8
ED 195	180	6,0	300	195	30	6,1
ED 265	240	8,0	395	265	36	11,7

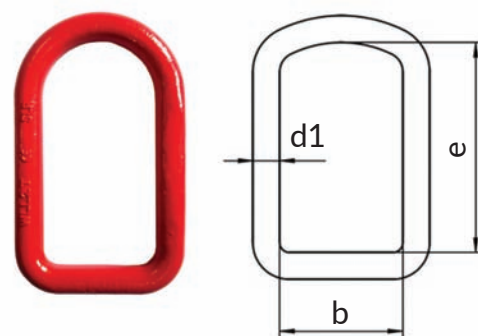

NAPINACZ ŁAŃCUCHOWY SRC

Typ	Lc [kN]	S [mm]		R [mm]		L [mm]	Masa [kg/szt.]
		min	max	min	max		
SRC 8-8	40	570	730	460	620	350	4,40
SRC 10-8	63	600	760	470	630	350	5,35
SRC 13-8	106	700	850	500	650	350	8,10
SRC 16-8	160	740	900	390	550	350	9,80

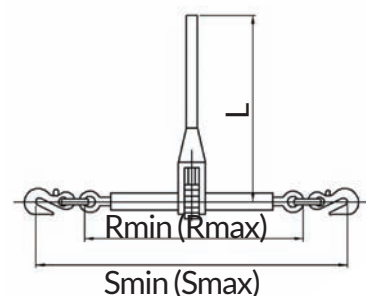

AKCESORIA ZAWIESIOWE KLASA 10



- Spełniają wymagania dyrektywy maszynowej 2006/42/WE
- Współczynnik bezpieczeństwa: 4
- Użyte materiały: stal w klasie 10 (wytrzymałość na rozciąganie 1000 N/mm²), 25% większy udźwig w stosunku do klasy 8, przy zachowaniu tej samej wagi
- Zwiększona odporność na ścieranie a tym samym dłuższa żywotność
- Łańcuch zabezpieczony przed korozją, komponenty malowane proszkowo
- Znakowanie: udźwig, znak CE, rozmiar, klasa wytrzymałości, symbol producenta
- Dokumenty: deklaracja zgodności, świadectwo jakości 2.1, certyfikat 3.1 na życzenie klienta, instrukcja użytkowania

OGNIWO GŁÓWNE AW

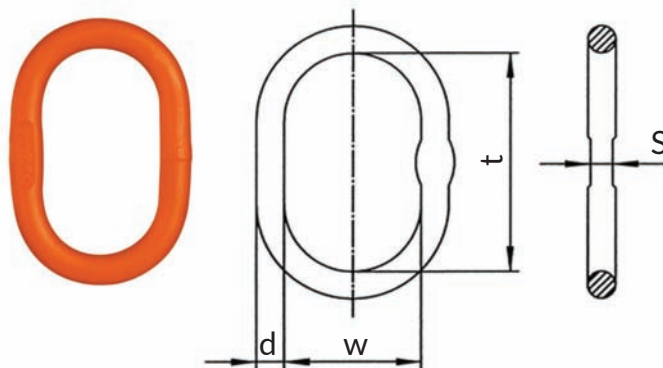

Typ	DOR przy kącie 0÷45° [kg]	Stosowane dla haka wg DIN 15401 max	d [mm]	t [mm]	w [mm]	s [mm]	Masa [kg/szt.]	Ogniwo główne do zawiesia o średnicy łańcucha [mm]	
								1- ciągnowego	2- ciągnowego
AW 10	1400	Nr 1,6	10	80	50	10	0,14	5	5
AW 13	2300	Nr 2,5	13	110	60	10	0,34	6+7	6
AW 16	3500	Nr 2,5	16	110	60	14	0,53	8	7
AW 18	5000	Nr 5	19	135	75	14	0,92	10	8
AW 22	7600	Nr 6	23	160	90	17	1,60	13	10
AW 26	10000	Nr 8	27	180	100	20	2,46	16	13
AW 32	14000	Nr 10	33	200	110	26	4,14	19	16
AW 36	25100	Nr 16	36	260	140	29	6,22	22	19
AW 45	30800	Nr 25	45	340	180	-	12,82	26	22
AW 50	40000	Nr 32	50	350	190	43	16,55	32	26
AW 56	64000	Nr 32	60	400	200	-	27,01	-	32
AW 72	85000	Nr 50	70	460	250	-	45,00	-	-

ZESTAW OGNIWOWY VW

Typ	Składa się z:	Dopuszczalne obciążenie robocze przy kącie 0÷45° [kg]	Stosowane dla haka wg DIN 15401	e [mm]	t [mm]	w [mm]	Masa [kg/szt.]
VW 5	AW 13 + 2 BW 10	2 300	Nr 2,5	154	110	60	0,52
VW 6	AW 18 + 2 BW 13	4 200	Nr 5	189	135	75	1,26
VW 7/8	AW 22 + 2 BW 16	7 600	Nr 6	230	160	90	2,32
VW 10	AW 26 + 2 BW 20	9 600	Nr 8	265	180	100	3,68
VW 13	AW 32 + 2 BW 22	14 000	Nr 10	315	200	110	6,46
VW 16	AW 36 + 2 BW 26	21 200	Nr 16	400	260	140	10,06
VW 19/20	AW 50 + 2 BW 32	34 100	Nr 32	500	350	190	22,87
VW 22	AW 50 + 2 BW 36	40 000	Nr 32	520	350	190	24,79
VW 26	AW 56 + 2 BW 45	56 000	Nr 32	570	400	200	41,31

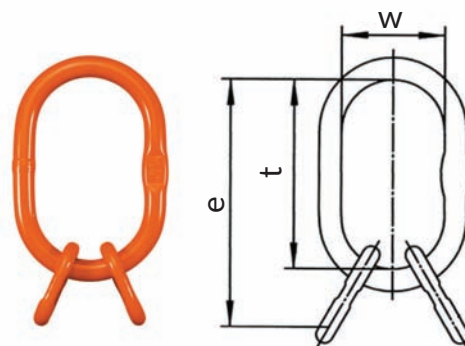

OGNIWO GŁÓWNE POWIĘKSZONE MW

Typ	DOR przy kącie 0÷45° [kg]	Stosowane dla haka wg DIN 15401	d [mm]	t [mm]	w [mm]	s [mm]	Masa [kg/szt.]	Ogniwo główne do łańcucha, średnica [mm]	
								1- ciągnowego	2- ciągnowego
MW 10	1 400	Nr 2,5	11	90	65	10	0,22	5	5
MW 13	2 300	Nr 4	14	120	70	10	0,44	6+7	6
MW 16	3 200	Nr 5	16	140	80	13	0,67	8	7
MW 18	4 200	Nr 6	19	160	95	14	1,09	10	8
MW 22	6 700	Nr 10	23	170	105	17	1,74	13	10
MW 26	10 100	Nr 10	27	190	110	20	2,65	16	13
MW 32	16 000	Nr 12	33	230	130	26	4,78	19	16
MW 36	21 200	Nr 20	38	275	150	29	7,48	22	19
MW 56	40 000	Nr 50	56	350	250	46	21,98	32	26

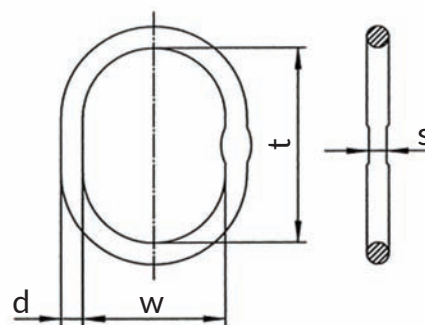

ZESTAW OGNIWOWY POWIĘKSZONY VMW

Typ	Składa się z:	Dopuszczalne obciążenie robocze przy kącie 0÷45° [kg]	Stosowane dla haka wg DIN 15401	e [mm]	t [mm]	w [mm]	Masa [kg/szt.]
VMW 6	MW 18 + 2 BW 13	4 200	Nr 6	214	160	95	1,43
VMW 7/8	MW 22 + 2 BW 16	6 600	Nr 10	240	170	105	2,46
VMW 10	MW 26 + 2 BW 20	10 100	Nr 10	275	190	110	4,01
VMW 13	MW 32 + 2 BW 22	15 700	Nr 12	345	230	130	6,90
VMW 16	MW 36 + 2 BW 26	21 200	Nr 20	415	275	150	11,12
VMW 19/20	MW 56 + 2 BW 32	34 100	Nr 50	500	350	250	28,08
VMW 22	MW 56 + 2 BW 36	40 000	Nr 50	520	350	250	30,62

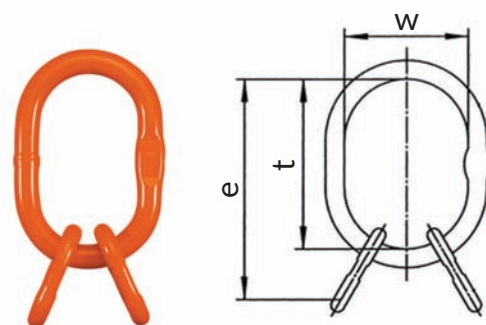

ZESTAW OGNIWOWY SPECJALNY VAW

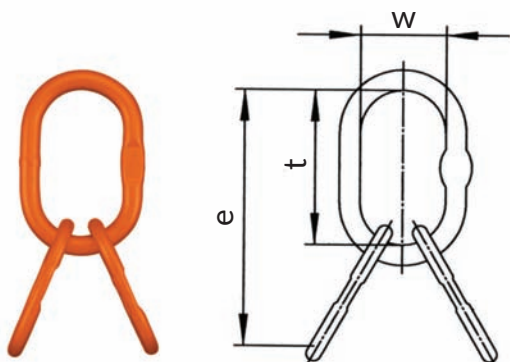

Typ	Składa się z:	Dopuszczalne obciążenie robocze przy kącie 0÷45° [kg]	Stosowane dla haka wg DIN 15401	e [mm]	t [mm]	w [mm]	Masa [kg/szt.]
VAW 6/7	AW 18 + 2 AW 14	5 000	Nr 5	245	135	75	1,72
VAW 8	AW 22 + 2 AW 16	6 300	Nr 6	270	160	90	2,66
VAW 10	AW 26 + 2 AW 18	9 500	Nr 8	315	180	100	4,30
VAW 13	AW 32 + 2 AW 26	16 100	Nr 10	380	200	110	9,06
VAW 16	AW 36 + 2 AW 32	25 100	Nr 16	460	260	140	14,50
VAW 19/20	AW 50 + 2 AW 36	41 100	Nr 32	625	350	190	31,51
VAW 22	AW 50 + 2 AW 45	47 400	Nr 32	690	350	190	42,19
VAW 26	AW 56 + 2 AW 50	58 000	Nr 32	750	400	200	60,11
VAW 32	AW 72 + 2 AW 56	85 000	Nr 50	860	460	250	99,02

OGNIWO GŁÓWNE VSAW

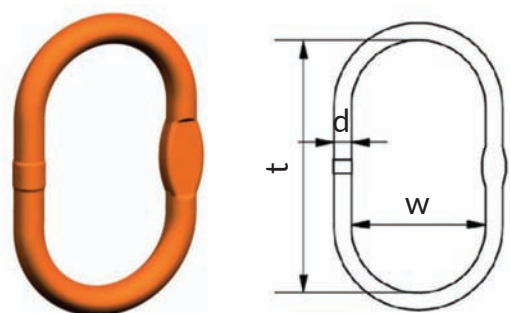

Typ	Zawiera	DOR [kg]	d [mm]	t [mm]	w [mm]	Masa [kg/szt.]
VSAW 1-10/13	SAW 32+BW 20	10.000	33	500	250	10.00
VSAW 1- 16	SAW 32	10.000	33	500	250	9.33
VSAW 1- 19	SAW 40	16.000	40	460	250	13.13
VSAW 1- 22	SAW 45	22.400	45	500	250	17.81
VSAW 1- 26	SAW 50	33.600	50	460	250	21.00
VSAW 1- 32	SAW 56	40.000	56	460	250	26.10
VSAW 1- 32 320	SAW 60	40.000	60	800	320	48.00

ZESTAW OGNIWOWY POWIĘKSZONY VLW 1

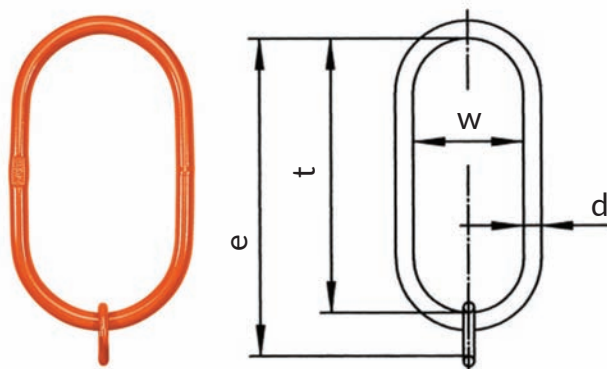

Typ	Składa się z:	DOR [kg]	Stosowane dla haka wg DIN 15401	e [mm]	d [mm]	t [mm]	w [mm]	s [mm]	Masa [kg/szt.]
VLW 1- 6/7/8	LW 22 + BW 13	2 500	Nr 25	394	22	340	180	17	3,40
VLW 1-10	LW 27 + BW 16	4 000	Nr 25	410	27	340	180	20	4,80
VLW 1-13	LW 27	6 700	Nr 25	340	27	340	180	20	4,40
VLW 1-16	LW 32	10 000	Nr 25	340	33	340	180	27	6,70
VLW 1-19/22	LW 40	19 000	Nr 25	340	40	340	180	29	10,00

ZESTAW OGNIWOWY POWIĘKSZONY VLW 2/4

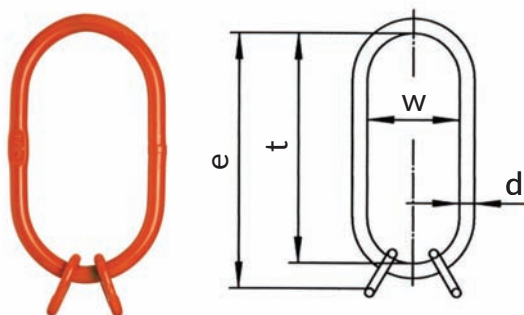

Typ	Składa się z:	DOR przy kącie 0÷45° [kg]	Stosowane dla haka wg DIN 15401	e [mm]	d [mm]	t [mm]	w [mm]	s [mm]	Masa [kg/szt.]
VLW 2-6/7/8/4-6	LW 22 + 2 BW 13	3 550	Nr 25	394	22	340	180	17	3,50
VLW 2-10/4-7/8	LW 27 + 2 BW 16	5 600	Nr 25	410	27	340	180	20	5,10
VLW 2-13/4-10	LW 32 + 2 BW 20	9 500	Nr 25	425	33	340	180	27	8,00
VLW 2-16/4-13	LW 40 + 2 BW 22	14 000	Nr 25	455	40	340	180	29	12,30
VLW 2-19/4-16	LW 40 + 2 BW 26	21 200	Nr 25	480	40	340	180	29	13,8

OGNIWO PRZEJŚCIOWE BW

Typ	DOR przy kącie 0÷45° [kg]	d [mm]	t [mm]	w [mm]	s [mm]	Masa [kg/szt.]	Ogniwo pośrednie dla łańcuchów 1 i 2-cięgnowych [mm]
BW 7	1 000	7	36	16	7	0,03	5
BW 8*	1 400	8	36	16	-	0,03	6
BW 9	1 900	9	44	20	-	0,07	7
BW 10	2 500	10	44	20	-	0,09	8
BW 13	4 000	13	54	25	10	0,17	10
BW 16	6 700	17	70	34	14	0,36	13
BW 20	10 000	20	85	40	14	0,68	16
BW 22	12 500	23	115	50	17	1,16	-
BW 23*	14 000	23	115	45	17	1,15	19
BW 26	16 200	27	140	65	20	1,92	-
BW 27*	19 000	27	140	55	20	1,92	22
BW 32	26 500	33	150	70	26	3,16	26
BW 36	31 000	36	170	75	-	4,12	-
BW 40	40 400	40	170	80	-	5,37	32
BW 45	42 400	45	170	80	-	7,15	-
BW 50	64 000	50	200	100	-	10,80	-
B 50	58 000	50	200	100	-	10,80	-

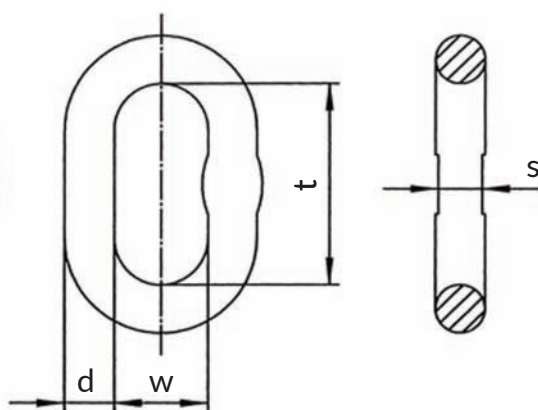

* tylko dla zawiesi zgrzewanych

OGNIWO POWIĘKSZONE VSAW1

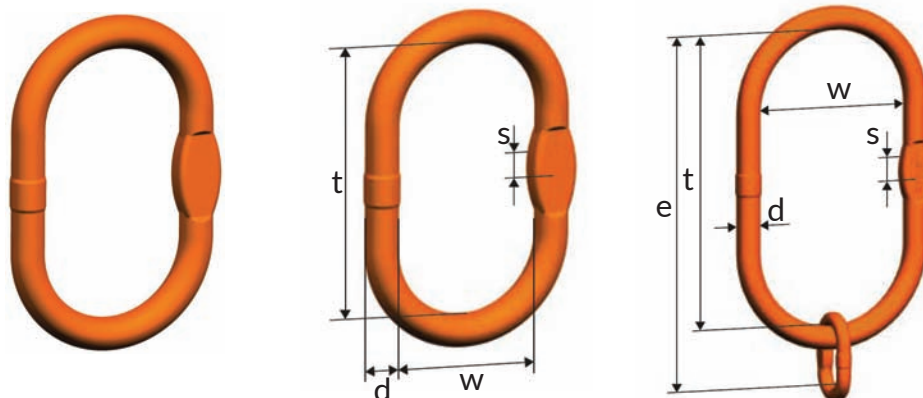

Typ	Składa się z:	DOR [kg]	Stosowane dla haka wg DIN 15401	e [mm]	d [mm]	t [mm]	w [mm]	Masa [kg/szt.]
VSAW 1-10/13	SAW 32+BW 20	10 000	Nr 50	585	33	500	250	10,00
VSAW 1-16	SAW 32	10 000	Nr 50	500	33	500	250	9,33
VSAW 1-19	SAW 40	16 000	Nr 50	460	40	460	250	13,13
VSAW 1-22	SAW 45	22 400	Nr 50	500	45	500	250	17,81
VSAW 1-26	SAW 50	33 600	Nr 50	460	50	460	250	21,00
VSAW 1-32	SAW 56	40 000	Nr 50	460	56	460	250	26,10
VSAW 1-32 320	SAW 60	40 000	Nr 100	800	60	800	320	48,00

ZESTAW OGNIWOWY POWIĘKSZONY VSAW2

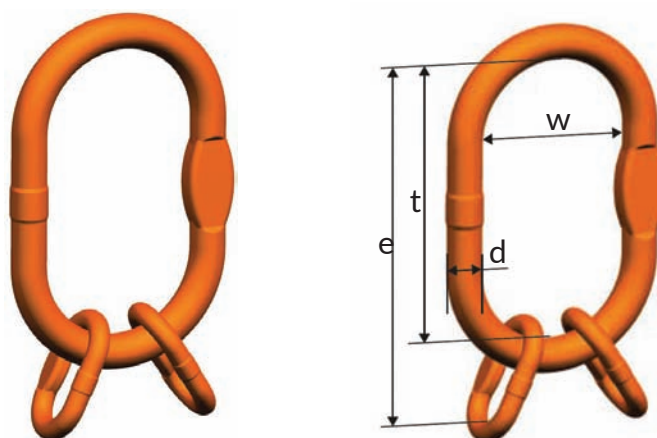

Typ	Składa się z:	DOR [kg]	Stosowane dla haka wg DIN 15401	e [mm]	d [mm]	t [mm]	w [mm]	Masa [kg/szt.]
VSAW 2-10/13/4-10	SAW 32+2 BW 20	9 500	Nr 50	585	33	500	250	10,69
VSAW 2-16/4-13	SAW 40+2 BW 22	14 000	Nr 50	575	40	460	250	15,45
VSAW 2-19/20/4-16	SAW 45+2 BW 26	21 200	Nr 50	640	45	500	250	21,65
VSAW 2-22/4-19/20	SAW 50+2 BW 32	30 000	Nr 50	610	50	460	250	27,32
VSAW 2-26/4-22	SAW 56+2 BW 32	40 000	Nr 50	610	56	460	250	34,30
VSAW 2-26/4-22/320	SAW 60+2 BW 32	40 000	Nr 100	950	60	800	320	54,32

OGNIWO WIDEŁKOWE KAGW 1

Typ	DOR [kg]	Dla łańcucha o średnicy:	Stosowane dla haka wg DIN 15401	d [mm]	t [mm]	w [mm]	e [mm]	Masa [kg/szt.]
KAGW 1-6	1.400	6	Nr 2,5	13	110	60	141	0,42
KAGW 1-7	1.900	7	Nr 2,5	13	110	60	153	0,54
KAGW 1-8	2.500	8	Nr 2,5	16	110	60	153	0,73
KAGW 1-10	4.000	10	Nr 5	19	135	75	186	1,28
KAGW 1-13	6.700	13	Nr 6	23	160	90	223	2,30
KAGW 1-16	10.000	16	Nr 8	27	180	100	254	3,67
KAGW 1-19/20	14.000	19	Nr 10	33	200	110	294	6,52
KAGW 1-22	19.000	22	Nr 16	36	260	362	362	9,43

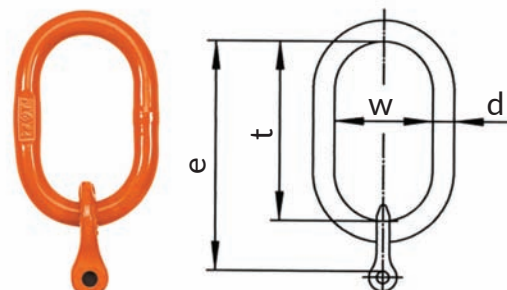
OGNIWO WIDEŁKOWE KAGW 2

Typ	DOR przy kącie 0÷45° /45÷60° [kg]	Dla łańcucha o średnicy:	Stosowane dla haka wg DIN 15401	d [mm]	t [mm]	w [mm]	e [mm]	Masa [kg/szt.]
KAGW 2-6	2.000/1.400	6	Nr 2,5	13	110	60	141	0,50
KAGW 2-7	2.650/1.900	7	Nr 2,5	16	110	60	153	0,93
KAGW 2-8	3.550/2.500	8	Nr 5	19	135	75	178	1,26
KAGW 2-10	5.600/4.000	10	Nr 6	23	160	90	211	2,32
KAGW 2-13	9.500/6.700	13	Nr 8	27	180	100	243	3,86
KAGW 2-16	14.000/10.000	16	Nr 10	33	200	110	274	6,56
KAGW 2-19/20	20.000/14.000	19	Nr 16	36	260	140	354	10,98
KAGW 2-22	26.500/19.000	22	Nr 25	45	340	180	442	19,24

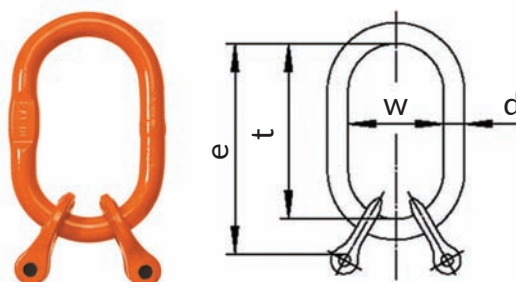
ZESTAW OGNIWOWY WIDEŁKOWY KAGW 4

Typ	DOR przy kącie 0÷45° /45÷60° [kg]	Dla łańcucha o średnicy:	Stosowane dla haka wg DIN 15401	d [mm]	t [mm]	w [mm]	e [mm]	Masa [kg/szt.]
KAGW 4-6	3.000/2.120	6	Nr 5	19	135	75	220	1,52
KAGW 4-7	4.000/2.800	7	Nr 6	23	160	90	272,5	3,12
KAGW 4-8	5.300/3.750	8	Nr 6	23	160	90	272,5	3,12
KAGW 4-10	8.000/6.000	10	Nr 8	27	180	100	316	5,12
KAGW 4-13	14.000/10.000	13	Nr 10	33	200	110	378	9,26
KAGW 4-16	21.200/15.000	16	Nr 16	36	260	140	474	14,90
KAGW 4-19/20	30.000/21.200	19	Nr 32	50	350	190	590	32,39
KAGW 4-22	40.000/28.000	22	Nr 32	50	350	190	617	37,63

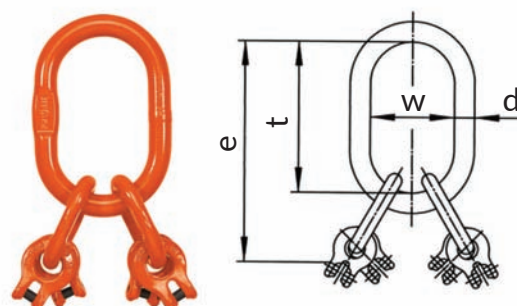

OGNIWO WIDEŁKOWE POWIĘKSZONE KMGW 1

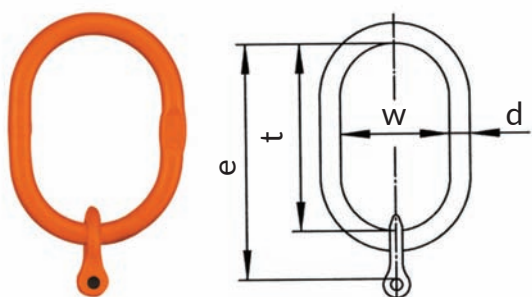

Typ	DOR [kg]	Dla łańcucha o średnicy:	Stosowane dla haka wg DIN 15401	d [mm]	t [mm]	w [mm]	e [mm]	Masa [kg/szt.]
KMGW 1-6	1.400	6	Nr 4	14	120	70	151	0,52
KMGW 1-8	2.500	8	Nr 5	16	140	80	183	0,87
KMGW 1-10	4.000	10	Nr 6	19	160	95	211	1,45
KMGW 1-13	6.700	13	Nr 10	23	170	105	233	2,44
KMGW 1-16	10.000	16	Nr 10	27	190	110	264	3,86

OGNIWO WIDEŁKOWE POWIĘKSZONE KMGW 2

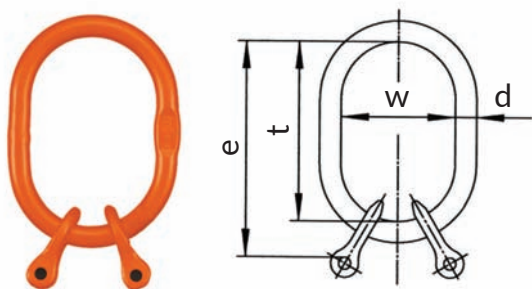

Typ	DOR przy kącie 0÷45°/45÷60° [kg]	Dla łańcucha o średnicy:	Stosowane dla haka wg DIN 15401	d [mm]	t [mm]	w [mm]	e [mm]	Masa [kg/szt.]
KMGW 2-6	2.000/1.400	6	Nr. 4	14	120	70	151	0,60
KMGW 2-8	3.550/2.500	8	Nr. 6	19	160	95	203	1,49
KMGW 2-10	5.600/4.000	10	Nr. 10	23	170	105	221	2,46
KMGW 2-13	9.500/6.700	13	Nr. 10	27	190	110	253	4,05
KMGW 2-16	14.000/10.000	16	Nr. 12	33	230	130	304	7,20

ZESTAW OGNIWOWY WIDEŁKOWY POWIĘKSZONY KMGW 4

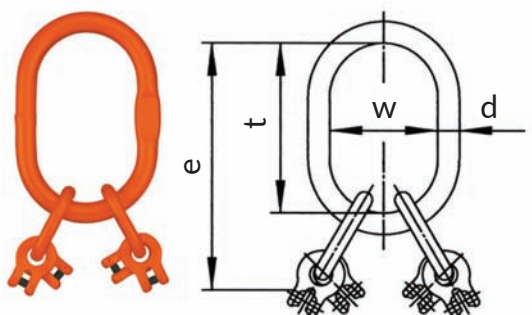

Typ	DOR przy kącie 0÷45°/45÷60° [kg]	Dla łańcucha o średnicy:	Stosowane dla haka wg DIN 15401	d [mm]	t [mm]	w [mm]	e [mm]	Masa [kg/szt.]
KMGW 4-6	3.000/2.120	6	Nr 6	19	160	95	245	1,75
KMGW 4-8	5.300/3.750	8	Nr 10	23	170	105	283	3,26
KMGW 4-10	8.000/6.000	10	Nr 10	27	190	110	326	5,45
KMGW 4-13	14.000/10.000	13	Nr 12	33	230	130	408	9,90
KMGW 4-16	21.200/15.000	16	Nr 20	38	275	150	489	16,00

OGNIWO WIDEŁKOWE VXKW 1

Typ	DOR [kg]	Dla łańcucha o średnicy:	Stosowane dla haka wg DIN 15401	d [mm]	t [mm]	w [mm]	e [mm]	Masa [kg/szt.]
VXKW 1-5	1.000	5	Nr 1,6	10	80	50	164	0,44
VXKW 1-6	1.400	6	Nr 2,5	13	110	60	194	0,64
VXKW 1-7	1.900	7	Nr 2,5	13	110	60	232	0,96
VXKW 1-8	2.500	8	Nr 2,5	16	110	60	232	1,16
VXKW 1-10	4.000	10	Nr 5	19	135	75	294	2,11
VXKW 1-13	6.700	13	Nr 6	23	160	90	363	4,30
VXKW 1-16	10.000	16	Nr 8	27	180	100	413	7,26

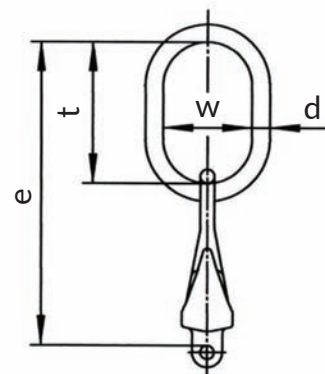

OGNIWO WIDEŁKOWE VXKW 2

Typ	DOR przy kącie 0÷45° / 45÷60° [kg]	Dla łańcucha o średnicy:	Stosowane dla haka wg DIN 15401	d [mm]	t [mm]	w [mm]	e [mm]	Masa [kg/szt.]
VXKW 2-5	1.400/1.000	5	Nr 1,6	10	80	50	164	0,74
VXKW 2-6	2.000/1.400	6	Nr 2,5	13	110	60	194	0,94
VXKW 2-7	2.650/1.900	7	Nr 2,5	16	110	60	232	1,77
VXKW 2-8	3.550/2.500	8	Nr 5	19	135	75	257	2,12
VXKW 2-10	5.600/4.000	10	Nr 6	23	160	90	319	4,10
VXKW 2-13	9.500/6.700	13	Nr 8	27	180	100	383	7,86
VXKW 2-16	14.000/10.000	16	Nr 10	33	200	110	433	13,74

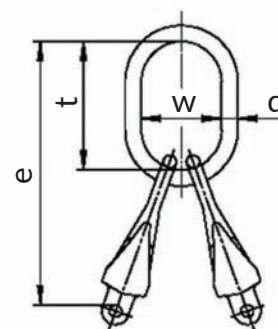

ZESTAW OGNIWOWY WIDEŁKOWY VXKW 4

Typ	DOR przy kącie 0÷45° / 45÷60° [kg]	Dla łańcucha o średnicy:	Stosowane dla haka wg DIN 15401	d [mm]	t [mm]	w [mm]	e [mm]	Masa [kg/szt.]
VXKW 4-5	2.000/1.500	5	Nr 2,5	13	110	60	238	1,72
VXKW 4-6	3.000/2.120	6	Nr 5	19	135	75	273	2,40
VXKW 4-7	4.000/2.800	7	Nr 6	23	160	90	352	4,84
VXKW 4-8	5.300/3.750	8	Nr 6	23	160	90	352	4,84
VXKW 4-10	8.000/6.000	10	Nr 8	27	180	100	424	8,82
VXKW 4-13	14.000/10.000	13	Nr 10	33	200	110	518	17,26
VXKW 4-16	21.200/15.000	16	Nr 16	36	260	140	633	29,26

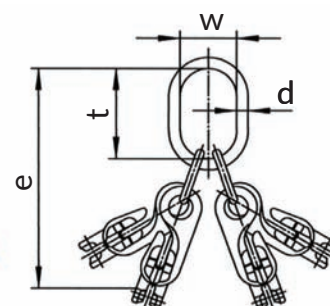

OGNIWO WIDEŁKOWE POWIĘKSZONE LXKW 1

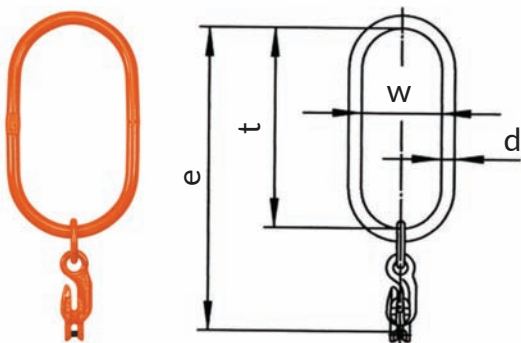

Typ	DOR [kg]	Stosowane dla haka wg DIN 15401	d [mm]	t [mm]	w [mm]	e [mm]	Masa [kg/szt.]
LXKW 1-6	1.400	Nr 25	23	340	180	478	3,70
LXKW 1-8	2.500	Nr 25	23	340	180	516	4,00
LXKW 1-10	4.000	Nr 25	27	340	180	569	6,00
LXKW 1-13	6.700	Nr 25	27	340	180	629	7,80
LXKW 1-16	10.000	Nr 25	33	340	180	688	12,70

OGNIWO WIDEŁKOWE POWIĘKSZONE LXKW 2

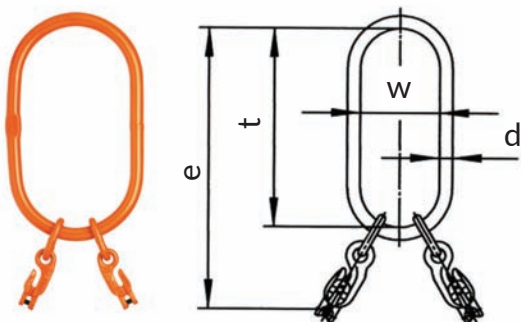

Symbol	DOR przy kącie 0÷45°/45÷60° [kg]	Stosowane dla haka wg DIN 15401	d [mm]	t [mm]	w [mm]	e [mm]	Masa [kg/szt.]
LXKW 2-6	2.000/1.400	Nr 25	23	340	180	478	4,14
LXKW 2-8	3.550/2.500	Nr 25	23	340	180	516	4,80
LXKW 2-10	5.600/4.000	Nr 25	27	340	180	569	7,60
LXKW 2-13	9.500/6.700	Nr 25	33	340	180	629	13,50
LXKW 2-16	14.000/10.000	Nr 25	40	340	180	688	21,90

ZESTAW OGNIWOWY WIDEŁKOWY POWIĘKSZONY LXKW 4

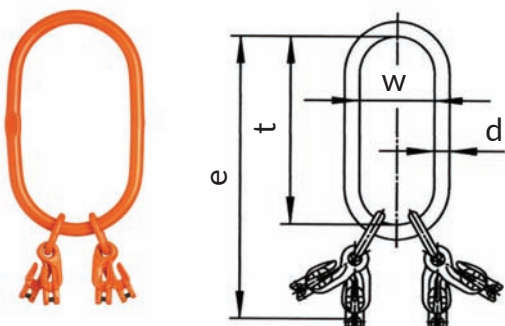

Symbol	DOR przy kącie 0÷45°/45÷60° [kg]	Stosowane dla haka wg DIN 15401	d [mm]	t [mm]	w [mm]	e [mm]	Masa [kg/szt.]
LXKW 4-6	3.000/2.120	Nr 25	23	340	180	478	4,70
LXKW 4-8	5.300/3.750	Nr 25	27	340	180	532	7,60
LXKW 4-10	8.000/6.000	Nr 25	33	340	180	584	13,10
LXKW 4-13	14.000/10.000	Nr 25	40	340	180	659	23,10
LXKW 4-16	21.200/15.000	Nr 25	40	340	180	713	33,10

ZŁĄCZKA ŁAŃCUCHOWA CONNEX CW

Typ	DOR [kg]	e [mm]	c [mm]	s [mm]	t [mm]	d [mm]	b [mm]	g [mm]	Masa [kg/szt.]
CW 5	1 000	36	7	9	10	7	35	13	0,05
CW 6	1 400	44	8	11	12	8	39	14	0,06
CW 7	1 900	51	10	13	14	9	47	17	0,12
CW 8	2 500	62	12	14	20	10	55	18	0,23
CW 10	4 000	72	15	18	22	13	64	24	0,42
CW 13	6 700	88	20	22	26	17	79	28	0,84
CW 16	10 000	103	21	29	31	21	106	33	1,40
CW 19/20	16 000	115	30	35	37	24	123	42	2,40
CW 22	19 000	161	34	39	42	25	148	51	4,15
CW 26	26 500	190	40	46	49	30	175	60	6,70
CW 32	40 000	206	47	56	63	35	216	80	11,20

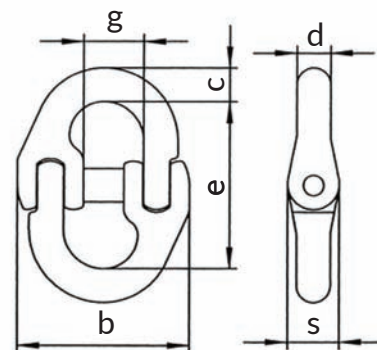

ZŁĄCZKA DO ZAWIESI WĘŻOWYCH CARW

Typ	DOR [kg]	a [mm]	e [mm]	c [mm]	d [mm]	b [mm]	s [mm]	g [mm]	Masa [kg/szt.]
CARW 8	2 500	29	66	112	11	65	18	18	0,40
CARW 10	4 000	40	81	15	13	82	21	24	0,55
CARW 13	6 700	50	104	20	17	100	28	28	1,20
CARW 16	10 000	47	113	21	21	110	40	33	2,00
CARW 22	19 000	109	178	29	27	215	59	48	6,50

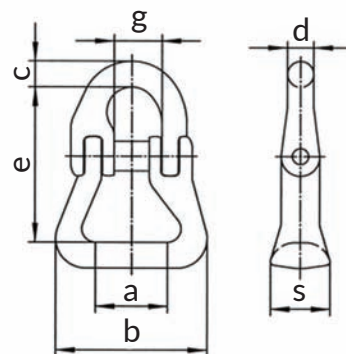

ŁAŃCUCH ZAWIESIOWY WIN 200

Typ	Średnica nominalna [d]	Pozdłużka [t]	Szerokość wewnętrzna [b1 min.]	Szerokość zewnętrzna [b2 max.]	DOR [kg]	Siła zrywająca [kN]	Masa [kg/szt.]
WIN 5 200	5	16	8	19	1.000	39,3	0,61
WIN 6 200	6	18	9	22	1.400	56,5	0,96
WIN 7 200	7	21	10	25	1.900	77	1,20
WIN 8 200	8	24	11	29	2.500	101	1,57
WIN 10 200	10	30	14	36	4.000	157	2,46
WIN 13 200	13	39	18	47	6.700	265	4,18
WIN 16 200	16	48	22	58	10.000	402	6,28
WIN 19 200	19	57	27	69	14.000	567	8,92
WIN 22 200	22	66	30	79	19.000	760	11,88
WIN 26 200	26	78	35	94	26.500	1.060	16,18
WIN 32 200	32	96	43	115	40.000	1.610	24,10

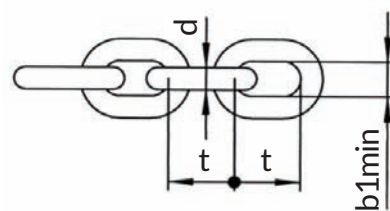

HAK SKRACAJĄCY PW

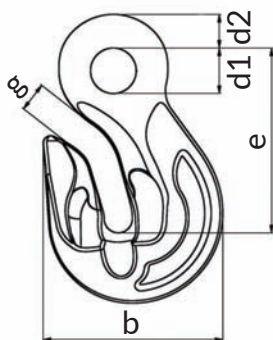

Typ	DOR [kg]	e [mm]	b [mm]	d1 [mm]	d2 [mm]	g [mm]	Masa [kg/szt.]
PW 5/6	1 400	51	48	12	9	8	0,18
PW 7/8	2 500	71	58	20	12	11	0,40
PW 10	4 000	88	76	22	15	13	0,90
PW 13	6 700	98	98	24	17	16	1,60
PW 16	10 000	129	118	32	23	19	3,60
PW 19/20	16 000	151	150	36	27	25	6,15
PW 22	19 000	170	165	42	31	27	8,30
PW 26	26 500	201	195	50	37	32	13,80
PW 32	40 000	243	242	60	43	38	25,00

HAK SKRACAJĄCY WIDEŁKOWY KPW

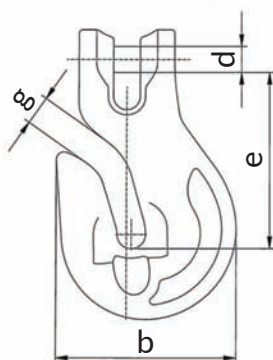

Typ	DOR [kg]	e [mm]	b [mm]	d [mm]	g [mm]	Masa [kg/szt.]
KPW 5/6	1 400	45	47	7	8	0,19
KPW 7	1 900	61	58	9	11	0,38
KPW 8	2 500	61	58	10	11	0,38
KPW 10	4 000	76	76	12,5	13	0,85
KPW 13	6 700	104	101	16	17	1,90
KPW 16	10 000	116	120	20	20	3,60
KPW 19/20	16 000	141	150	24	25	6,15
KPW 22	19 000	158	165	27	27	9,00

HAK SKRACAJĄCY WIDEŁKOWY Z ZABEZPIECZENIEM KPSW

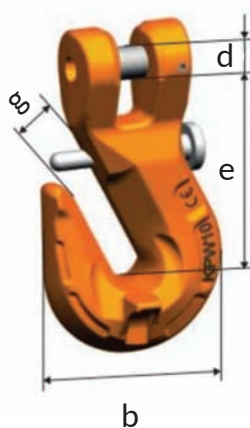

Typ	DOR [kg]	e [mm]	b [mm]	d [mm]	g [mm]	Masa [kg/szt.]
KPSW 7	1 900	63	57	9	9	0,44
KPSW 8	2 500	63	57	10	9	0,44
KPSW 10	4 000	78	71	12,50	12	0,85
KPSW 13	6 700	93	92	16	15	1,75
KPSW 16	10 000	115	113	20	19	3,30

HAK SKRACAJĄCY XKW

Typ	DOR [kg]	e [mm]	b [mm]	a [mm]	d1 [mm]	d2 [mm]	g [mm]	Masa [kg/szt.]
XKW 5/6	1 400	84	37	29	18	9	8	0,30
XKW 7	1 900	122	54	39	24	12	11	0,62
XKW 8	2 500	122	54	39	24	12	11	0,62
XKW 10	4 000	159	70	50	31	14	13	1,25
XKW 13	6 700	203	92	64	37	18	15	2,70
XKW 16	10 000	234	102	80	48	24	20	4,80

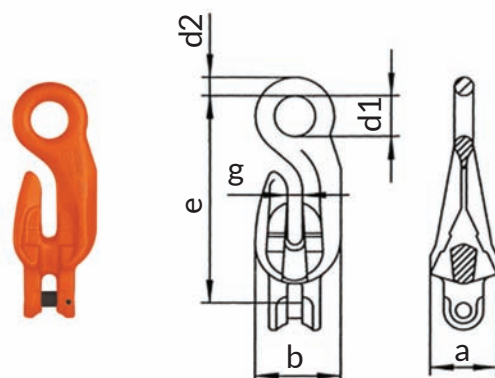

HAK SKRACAJĄCY Z ZABEZPIECZENIEM PSW

Typ	DOR [kg]	e [mm]	b [mm]	d1 [mm]	d2 [mm]	g [mm]	Masa [kg/szt.]
PSW 7/8	2.500	71	58	20	12	11	0,40
PSW 10	4.000	88	76	22	15	13	0,90
PSW 13	6.700	98	98	24	17	16	1,60
PSW 16	10.000	129	118	32	23	19	3,60

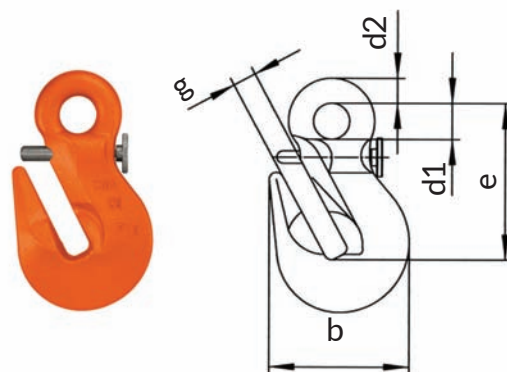

HAK Z ZABEZPIECZENIEM WIDEŁKOWY KHSW

Typ	DOR [kg]	e [mm]	h [mm]	a [mm]	d [mm]	g1 [mm]	b [mm]	Masa [kg/szt.]
KHSW 5/6	1 400	69	20	15	7	19	66	0,20
KHSW 7	1 900	95	28	19	9	26	90	0,60
KHSW 8	2 500	95	28	19	10	26	90	0,60
KHSW 10	4 000	109	35	25	12,50	31	108	1,10
KHSW 13	6 700	136	41	34	16	39	131	2,00
KHSW 16	10 000	155	49	37	20	45	153	3,48
KHSW 19/20	16 000	184	53	51	24	53	177	5,00

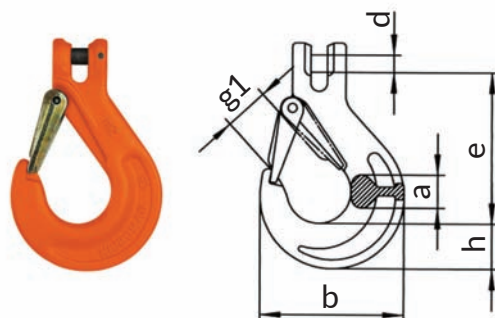

HAK Z ZABEZPIECZENIEM HSW

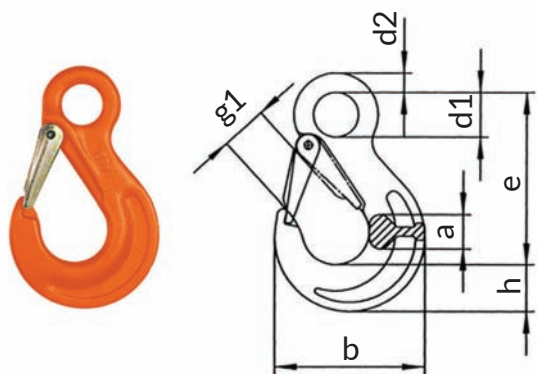

Typ	DOR [kg]	e [mm]	h [mm]	a [mm]	d1 [mm]	d2 [mm]	g1 [mm]	b [mm]	Masa [kg/szt.]
HSW 5/6	1 000	85	21	17	20	10	19	68	0,30
HSW 7/8	2 500	106	27	19	25	11	26	88	0,50
HSW 10	4 000	131	33	26	34	16	31	109	1,10
HSW 13	6 700	164	44	33	43	19	39	134	2,20
HSW 16	10 000	183	50	40	50	25	45	155	3,50
HSW 19/20	16 000	205	55	48	55	27	53	178	5,80
HSW 22	19 000	225	62	50	60	29	62	196	8,00
HSW 26	26 500	259	75	70	70	37	73	235	13,40
HSW 32	40 000	299	97	82	66	45	87	291	27,50
HS 32	31 500	299	89	78	66	42	87	281	22,4

HAK KONTENEROWY WIDEŁKOWY KFW

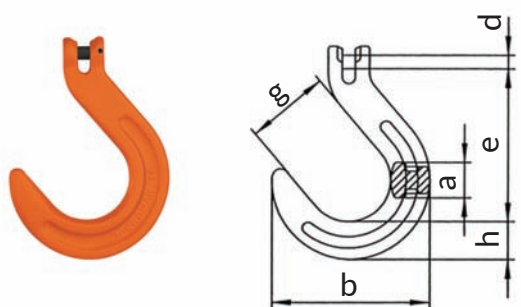

Typ	DOR [kg]	e [mm]	h [mm]	a [mm]	g [mm]	d [mm]	b [mm]	Masa [kg/szt.]
KFW 7	1.900	121	29	25	64	9	118	1,00
KFW 8	2.500	120	29	25	64	10	118	1,00
KFW 10	4.000	140	35	32	76	12,50	143	1,78
KFW 13	6.700	170	42	40	89	16	170	2,96

HAK KONTENEROWY FW

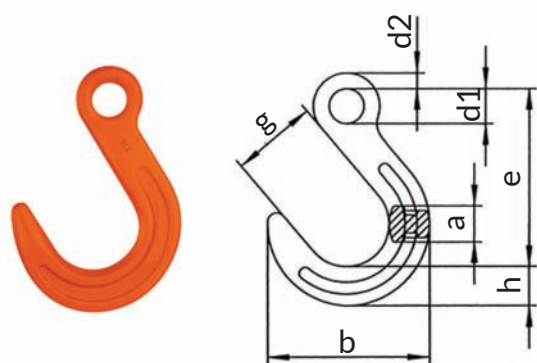

Typ	DOR [kg]	e [mm]	h [mm]	a [mm]	d1 [mm]	d2 [mm]	g [mm]	b [mm]	Masa [kg/szt.]
FW 7/8	2.500	131	29	25	24	11	64	118	0,92
FW 10	4.000	158	35	32	31	14	76	143	1,77
FW 13	6.700	190	42	40	39	17	89	170	2,82
FW 16	10.000	224	50	46	47	22	102	200	5,03
FW 19/20	16.000	260	61	54	56	28	114	231	9,24
FW 22	15.000	265	70	61	47	30	127	260	9,31
FW 26*	21.200	305	80	72	54	34	136	280	19,21
FW 32	31.500	327	93	83	60	37	152	336	28,00

HAK BEZPIECZNY WIDĘŁKOWY KLHW

Typ	DOR [kg]	e [mm]	h [mm]	a [mm]	b [mm]	d [mm]	g [mm]	s max [mm]	Masa [kg/szt.]
KLHW 5/6	1 400	94	20	17	71	7	28	1	0,50
KLHW 7	1 900	123	26	20	88	9	34	1	0,90
KLHW 8	2 500	123	26	20	88	10	34	1	0,90
KLHW 10	4 000	144	30	29	107	12,50	45	1	1,60
KLHW 13	6 700	180	40	35	138	16	52	1,50	2,90
KLHW 16	10 000	218	50	41	168	20	60	2	5,80
KLHW 19/20	16 000	259	62	50	194	24	70	2	9,90
KLHW 22	19 000	286	65	52	211	27	81	2	12,80
KLHW 26	26 500	338	79	61	253	33	100	2	20,50

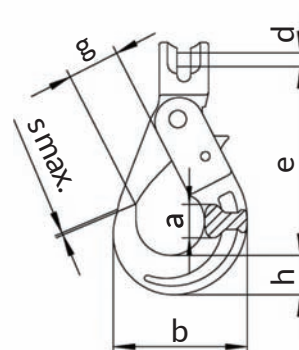

HAK BEZPIECZNY LHW

Typ	DOR [kg]	e [mm]	h [mm]	a [mm]	b [mm]	d1 [mm]	d2 [mm]	g [mm]	s max [mm]	Masa [kg/szt.]
LHW 5/6	1 400	110	20	17	71	21	11	28	1	0,50
LHW 7/8	2 500	136	26	20	88	25	12	34	1	0,90
LHW 10	4 000	169	30	29	107	34	15	45	1	1,50
LHW 13	6 700	205	40	35	138	43	20	52	1,50	2,70
LHW 16	10 000	251	50	41	168	50	27	60	2	5,70
LHW 19/20	16 000	290	62	50	194	55	30	70	2	9,80
LHW 22	19 000	322	65	52	211	60	32	81	2	12,40

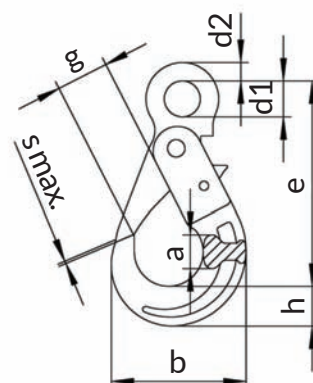

HAK OBROTOWY BEZPIECZNY WLHW

Typ	DOR [kg]	e [mm]	h [mm]	a [mm]	w [mm]	w1 [mm]	d2 [mm]	g [mm]	s max [mm]	Masa [kg/szt.]
WLHW 6	1.400	160	20	17	35	35	13	28	1	0,60
WLHW 7/8	2.500	181	26	20	35	35	13	34	1	1,10
WLHW 10	4.000	218	30	29	41	40	16	45	1	2,00
WLHW 13	6.700	269	40	35	49	47	20	52	1,50	4,00
WLHW 16	10.000	319	50	41	60	60	24	60	2	6,80

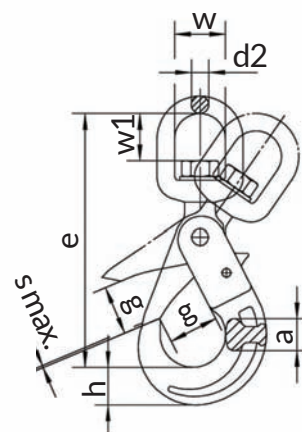

HAK OBROTOWY BEZPIECZNY WLHW

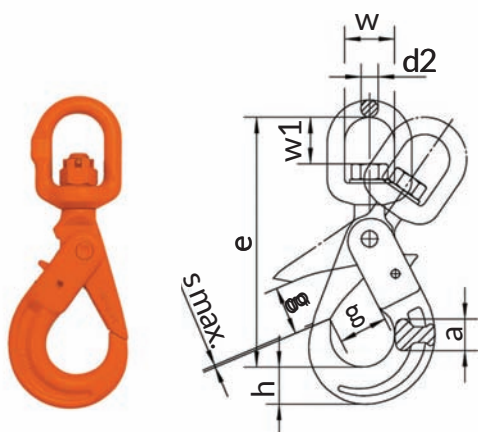

Typ	DOR [kg]	e [mm]	h [mm]	a [mm]	w [mm]	w1 [mm]	d2 [mm]	g [mm]	s_max [mm]	Masa [kg/szt.]
WLHW 6	1.400	160	20	17	35	35	13	28	1	0,60
WLHW 7/8	2.500	181	26	20	35	35	13	34	1	1,10
WLHW 10	4.000	218	30	29	41	40	16	45	1	2,00
WLHW 13	6.700	269	40	35	49	47	20	52	1,50	4,00
WLHW 16	10.000	319	50	41	60	60	24	60	2	6,80

OGNIWO WIDŁKOWE KOW

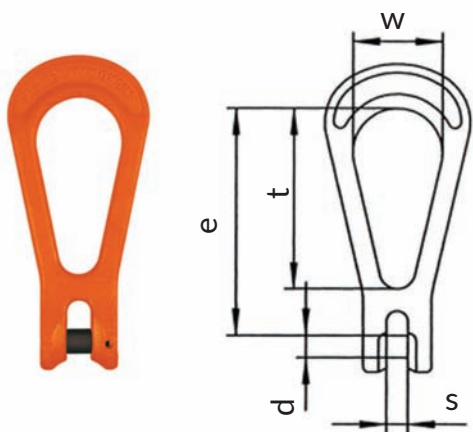

Typ	DOR [kg]	e [mm]	t [mm]	w [mm]	d [mm]	s [mm]	Masa [kg/szt.]
KOW 7	1 900	92	70	34	9	9	0,28
KOW 8	2 500	91	70	34	10	9	0,30
KOW 10	4 000	128	102	50	13	12	0,70
KOW 13	6 700	169	136	66	16	15	1,40
KOW 16	10 000	214	172	83	20	18	2,74

ZŁĄCZKA ŁAŃCUCHOWA KRW

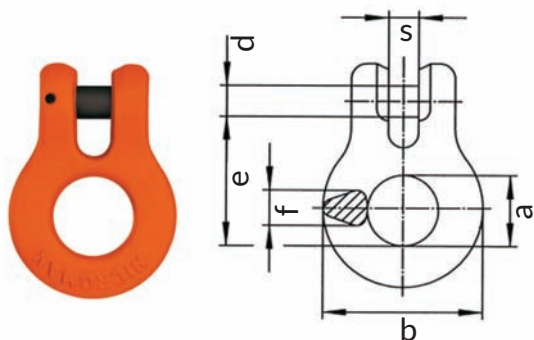

Typ	DOR [kg]	e [mm]	s [mm]	a [mm]	b [mm]	f [mm]	d [mm]	Masa [kg/szt.]
KRW 5/6	1400	31	7	18	38	8	7	0,08
KRW 7	1900	43	10	24	54	11	9	0,20
KRW 8	2500	43	10	24	54	11	10	0,20
KRW 10	4000	51	12	28	63	14	12,50	0,36
KRW 13	6700	63	15	33	76	17	16	0,70
KRW 16	10000	74	18	40	88	20	20	1,21
KRW 19/20	16000	94	23	50	114	24	24	2,38
KRW 22	19000	102	25	50	122	27	27	3,21

SZAKLA WIDĘŁKOWA KSCHW

Typ	DOR [kg]	e [mm]	e1 [mm]	b [mm]	a [mm]	d [mm]	c [mm]	d1 [mm]	Masa [kg/szt.]
KSCHW 7	1900	76	54	26	12	9	31	16	0,49
KSCHW 8	2500	76	54	26	12	10	31	16	0,49
KSCHW 10	4000	105	76	32	16	12,50	39	20	0,95
KSCHW 13	6700	113	77	42	21	16	50	24	1,89

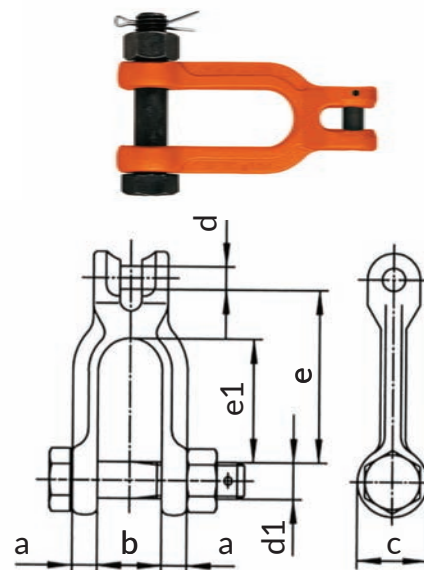

BLOKADA KNEW



Typ	DOR [kg]	e [mm]	a [mm]	b [mm]	c [mm]	d1 [mm]	d2 [mm]	d min [mm]	d max [mm]
KNEW 8	2500	10	17	120	38	15	15	40	60

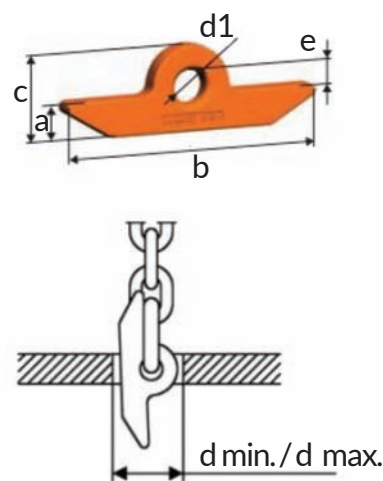

HAK BWW DO PODNOSZENIA PŁYT

Typ	DOR [kg]	e [mm]	s [mm]	b [mm]	h [mm]	d1 [mm]	g [mm]	Masa [kg/szt.]
BWW 7/8	2.500	131	80	50	18	28	55	1,50
BWW 10	4.000	168	100	70	20	36	65	2,80
BWW 13	6.700	207	130	80	26	40	90	5,30
BWW 16	10.000	261	160	100	33	50	110	10,50
BWW 19/20	16.000	302	185	120	40	60	130	17,50
BWW 22	19.000	363	220	140	50	75	150	30,50

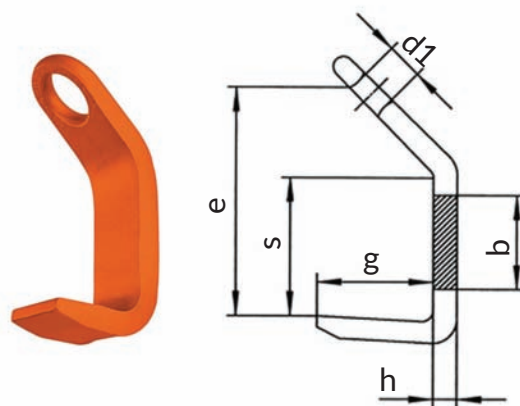

HAK DO PRZYSPAWANIA AWHW

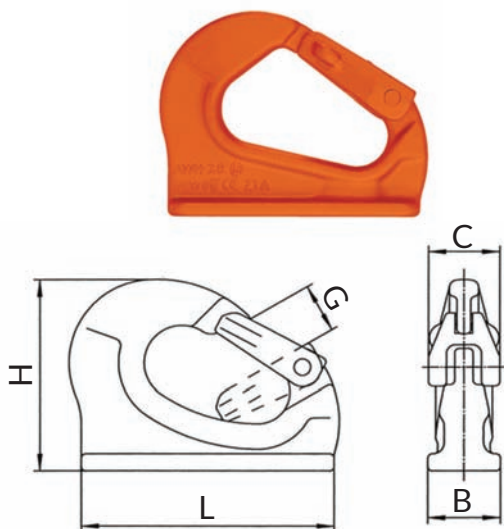

Typ	DOR [kg]	L [mm]	H [mm]	G [mm]	B [mm]	C [mm]	Masa [kg/szt.]
AWHW 1,3	1.300	95	74	25	25	34	0,60
AWHW 3,8	3.800	132	106	29	35	40	1,30
AWHW 6,3	6.300	167	133	34	45	49	2,80
AWHW 10	10.000	175	136	34	50	49	3,70

HAK KCHW

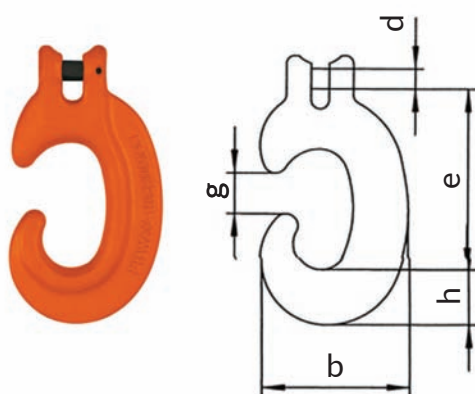

Typ	DOR [kg]	e [mm]	h [mm]	d [mm]	b [mm]	g [mm]	Masa [kg/szt.]
KCHW 7	1 900	91	28	9	74	20	0,50
KCHW 8	2 500	90	28	10	74	20	0,50
KCHW 10	4 000	129	39	12,50	107	28	1,40
KCHW 13	6 700	166	51	16	137	41	3,00
KCHW 16	10 000	205	60	20	166	45	5,30

HAK WIDŁOWY DO PAKIETÓW BLACH GHW

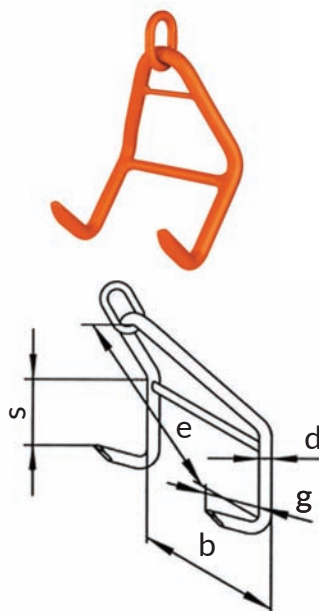

Typ	DOR [kg]	s [mm]	b [mm]	g [mm]	d [mm]	e [mm]	łączyć z ogniwnem pośrednim BW	Masa [kg/szt.]
GHW 5/6	1 400	100	190	65	23	203	BW 13	2,80
GHW 7/8	2 500	150	254	100	30	300	BW 16	6,50
GHW 10	4 000	200	380	130	40	402	BW 22	16,10
GH 13	5 300	300	500	195	50	592	BW 26	36,50
GH 16	8 000	400	600	250	60	781	BW 26	64,50

KRĘTLIK DFW

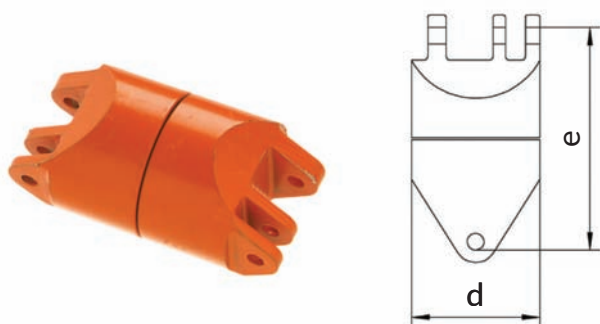

Typ	DOR [kg]	e [mm]	d [mm]	Masa [kg/szt.]
DFW 7	1 900	91	53	1,12
DFW 8	2 500	92	53	1,12
DFW10	4 000	111	63	2,00

*Krętlik umożliwia obracanie ładunkiem pod obciążeniem

NAPINACZ ŁAŃCUCHOWY RSPSW

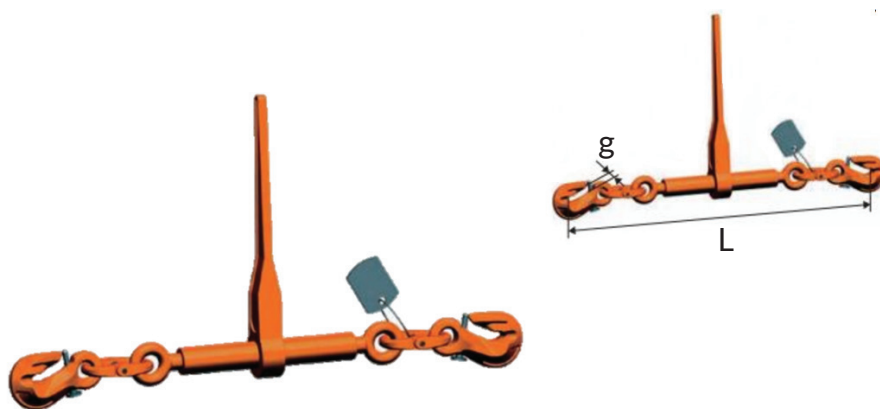

Typ	Znak	LC Zdolność mocowania [kN]	STF Siła nominalnego napięcia [daN]	Długość L (zamknięte) [mm]	Długość L (otwarty) [mm]	Długość ramienia L [mm]	Otwarcie g [mm]	Masa [kg/szt.]
RSPSW 8	Typ A	50	1,900	621	766	237	11	4,40
RSPSW 10	Typ B	80	3,000	685	830	355	13	6,30
RSPSW 13	Typ C	134	2,500	978	1,268	359	17	15,00

SZAKŁA OKRĄGŁA GSCHW

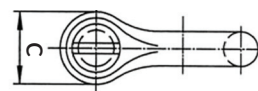
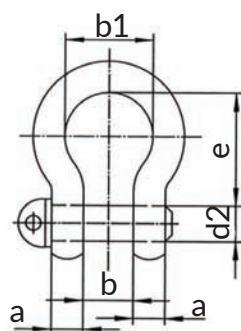

Typ	Dopuszczalne obciążenie robocze [kg]	e [mm]	b [mm]	b1 [mm]	a [mm]	c [mm]	d2 [mm]	Masa [kg/szt.]
GSCHW 10	4000	64	27	43	16	40	19	0,64
GSCHW 13	6700	76	31	51	19	46	22	1,03
GSCHW 16	10000	95	43	68	25	59	28	2,23
GSCH 19	11000	95	43	68	25	57	28	2,20

SZAKŁA PODŁUŻNA SCHW

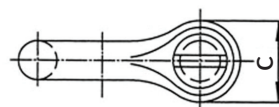
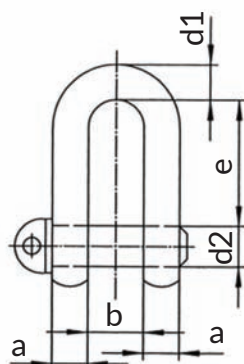

Typ	DOR [kg]	e [mm]	b [mm]	a [mm]	d1 [mm]	c [mm]	d2 [mm]	Masa [kg/szt.]
SCHW 5	1.000	24	11	7	8	16	8	0,05
SCHW 6	1.400	30	14	8	10	20	10	0,09
SCHW 7/8	2.500	36	17	10	12	24	12	0,20
SCHW 10	4.000	49	21	13	15	32	16	0,30
SCHW 13	6.700	61	27	17	19	40	20	0,70
SCHW 16	10.000	73	33	21	23	48	24	1,30
SCH 19	11.200	73	33	21	23	48	24	1,30





AMP22-128

AKCESORIA ZAWIESIOWE KLASA 12



- Spełniają wymagania dyrektywy maszynowej 2006/42/WE
- Współczynnik bezpieczeństwa: 4
- Użyte materiały: stal w klasie 12 (wytrzymałość na rozciąganie 1200 N/mm²), 50% większy udźwig w stosunku do klasy 8 w tym samym rozmiarze zawiesia
- Zwiększona odporność na ścieranie a tym samym dłuższa żywotność
- Łańcuch zabezpieczony przed korozją, komponenty malowane proszkowo
- Znakowanie: udźwig, znak CE, rozmiar, klasa wytrzymałości, symbol producenta
- Dokumenty: deklaracja zgodności, świadectwo jakości 2.1, certyfikat 3.1 na życzenie, instrukcja użytkowania

OGNIWO AWP

Typ	DOR przy kącie 0÷45° [kg]	d [mm]	t [mm]	w [mm]	s [mm]	Masa [kg/szt.]	Ogniwo główne do zawiesia o średnicy łańcucha [mm]	
							1- ciągnowego	2- ciągnowego
AWP 13	2.360	13	110	60	10	0,34	7	-
AWP 16	3.500	17	110	60	14	0,53	8	7
AWP 18	5.300	19	135	75	14	0,92	10	8
AWP 22	8.000	23	160	90	17	1,60	13	10
AWP 27	11.200	28	200	110	21	2,85	-	13

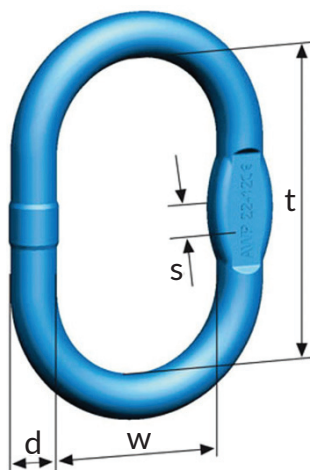

OGNIWO POWIĘKSZONE MWP

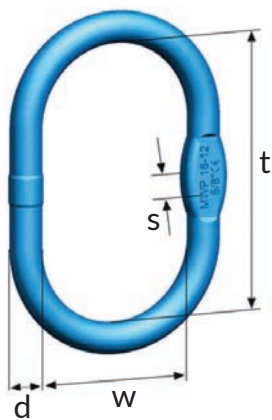

Typ	DOR przy kącie 0÷45° [kg]	d [mm]	t [mm]	w [mm]	s [mm]	Masa [kg/szt.]	Ogniwo główne do zawiesia 1-cięgnowego o średnicy łańcucha [mm]
MWP 13	2.360	14	120	70	10	0,44	7
MWP 16	3.200	17	140	80	13	0,67	8
MWP 18	5.000	19	160	95	14	1,21	10
MWP 26	10.100	27	190	110	20	2,65	13

ZESTAW OGNIWOWY VMWP

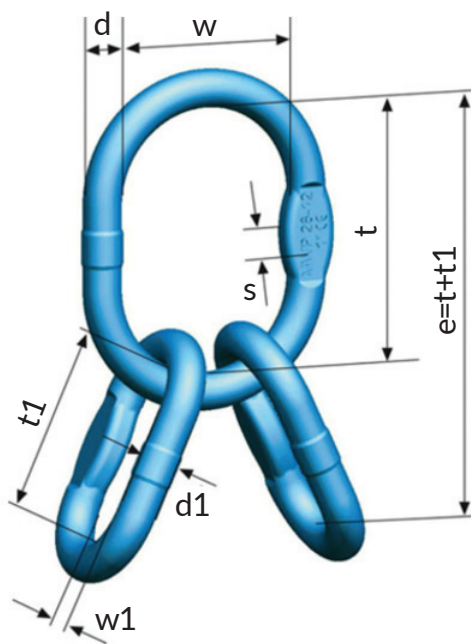

Typ	Składa się z:	Do zawiesia 2-cięgnowego	Do zawiesia 3 i 4 - cięgnowego	DOR dla kątów 0÷45° [kg]	e [mm]	d [mm]	t [mm]	w [mm]	d1 [mm]	t1 [mm]	w1 [mm]	Masa [kg/szt.]
VMWP 7/8	MWP 18 + 2 BWP 13	7+8	-	4.250	214	19	160	95	13	54	25	1,55
VMWP 10/7/8	MWP 26 + 2 BWP 16	10	7+8	8.800	260	27	190	110	17	70	34	3,37
VMWP 13/10	MWP 32 + 2 BWP 20	13	10	12.300	315	33	230	130	20	85	40	6,00
VMWP -/13	MWP 36 + 2 BWP 26	-	13	21.200	415	38	275	150	27	140	65	11,1
VMWP -/16	MWP 36 + 2 BWP 32	-	16	26.500	425	38	275	150	33	150	70	13,8

OGNIWO POWIĘKSZONE VLWP 1

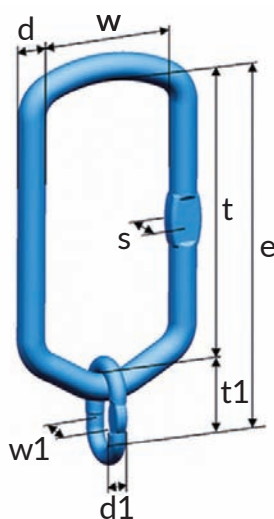

Typ	Składa się z:	DOR dla kątów 0÷45° [kg]	e [mm]	d [mm]	t [mm]	w [mm]	d1 [mm]	t1 [mm]	w1 [mm]	Masa [kg/szt.]	Do zawiesia 1- ciągnowego
VLWP 1-7/8	LWP 22 + 13	3000	394	23	340	155	13	54	25	3,37	7+8
VLWP 1-10	LWP 26 + BWP 16	5000	410	26	340	155	17	70	34	3,56	10
VLWP 1-13	LWP 26	8000	340	28	340	155	-	-	-	4,40	13
VLWP 1-16	LWP 33	12500	340	33	340	155	-	-	-	6,60	16

ZESTAW OGNIWOWY POWIĘKSZONY VLWP 2/4

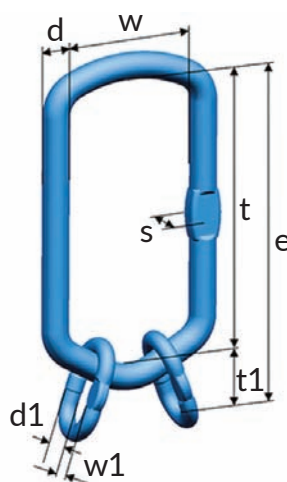

Typ	Składa się z:	DOR dla kątów 0÷45° [kg]	e [mm]	d [mm]	t [mm]	w [mm]	d1 [mm]	t1 [mm]	w1 [mm]	Masa [kg/szt.]	Do zawiesia 1-ciągnowego	Do zawiesia 3 i 4- ciągnowego
VLWP 2-7/8	LWP 22 + 2 BWP 13	4250	394	23	340	155	13	54	25	3,6	7+8	-
VLWP 2-10/4-7/8	LWP 26 + 2 BWP 16	7100	410	27	340	155	17	70	34	5,2	10	7/8
VLWP 2-13/4-10	LWP 32 + 2 BWP 26	11200	425	33	340	155	20	85	40	8	13	10
VLWP 4-13	LWP 36 + 2 BWP 26	17000	480	38	340	155	27	140	65	12,8	-	13
VLWP 2-16	LWP 36	17500	340	38	340	155	-	-	-	8,9	16	-
VLWP 4-16	LWP 40 + 2 BWP 32	26500	490	40	340	155	33	150	70	16,3	-	16

ZŁĄCZKA ŁAŃCUCHOWA CWP

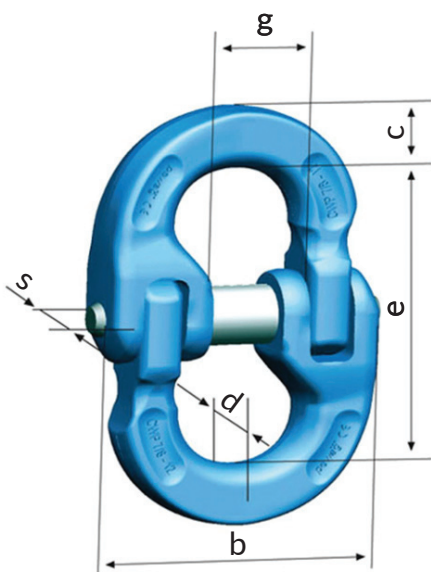

Typ	DOR [kg]	e [mm]	c [mm]	s [mm]	d [mm]	b [mm]	g [mm]	Masa [kg/szt.]
CWP 7	2.360	51	11	14	9	47	16	0,12
CWP 8	3.000	58	12	16	11	57	21	0,26
CWP 10	5.000	70	16	20	13	66	22	0,33
CWP 13	8.000	95	21	24	17	84	26	0,70

HAK SKRACAJĄCY PWP

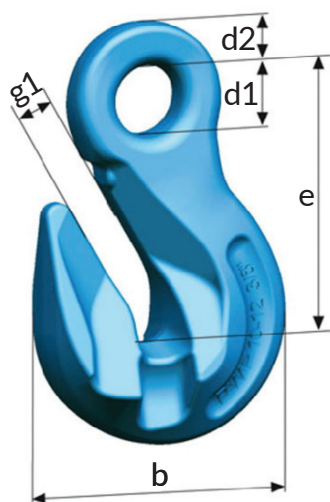

Typ	DOR [kg]	e [mm]	b [mm]	d1 [mm]	d2 [mm]	g1 [mm]	Masa [kg/szt.]
PWP 7/8	3.000	68	63	18	11	10	0,43
PWP 10	5.000	88	81	22	14	13	1,03
PWP 13	8.000	110	103	26	18	17	2,10

HAK SKRACAJĄCY Z ZABEZPIECZENIEM PSWP

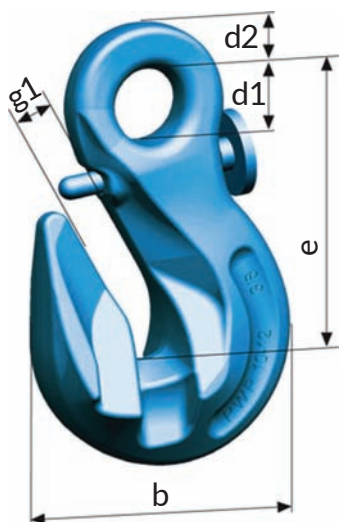

Typ	LC Zdolność mocowania [kN]	e [mm]	b [mm]	d1 [mm]	d2 [mm]	g1 [mm]	Masa [kg/szt.]
PSWP 7/8	60	68	63	18	11	10	0,53
PSWP	100	88	81	22	14	13	1,05
PSWP 13	160	110	103	26	18	17	1,89

ŁAŃCUCH ZAWIESIOWY WINPRO

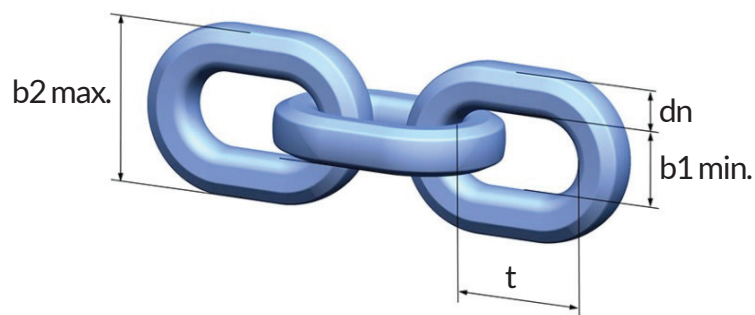

Typ	Szerokość łańcucha dn [mm]	Standardowa długość dostarczana [m]	Podziałka [t]	Szerokość wewnętrzna [b1 min.]	Szerokość zewnętrzna [b2 max.]	Dopuszczalne obciążenie robocze [kg]	Siła zrywająca [kN]	Masa [kg/szt.]
WINPRO 7	7	50	22	10	26	2.360	92,60	1,28
WINPRO 8	8	50	25	11	29	3.000	118,00	1,64
WINPRO 10	10	50	33	14	37	5.000	196,00	2,66
WINPRO 13	13	50	41	19	50	8.000	314,00	4,5

HAK Z ZABEZPIECZENIEM HSWP

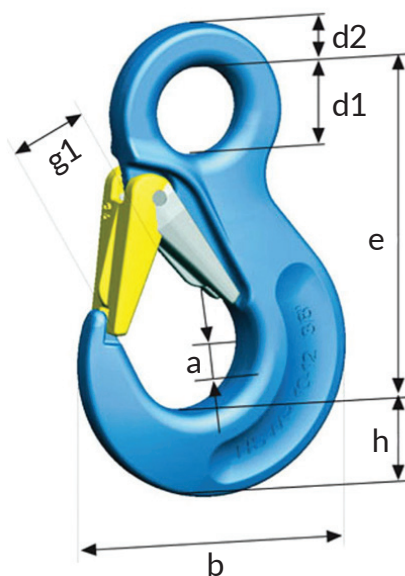

Typ	DOR [kg]	e [mm]	h [mm]	a [mm]	d1 [mm]	d2 [mm]	g1 [mm]	b [mm]	Masa [kg/szt.]
HSWP 7/8	3.000	106	27	19	25	11	26	88	0,50
HSWP 10	5.000	131	33	26	34	16	31	108	1,10
HSWP 13	8.000	164	43	33	43	19	39	132	2,20

HAK Z ZABEZPIECZENIEM KHSWP WIDEŁKOWY

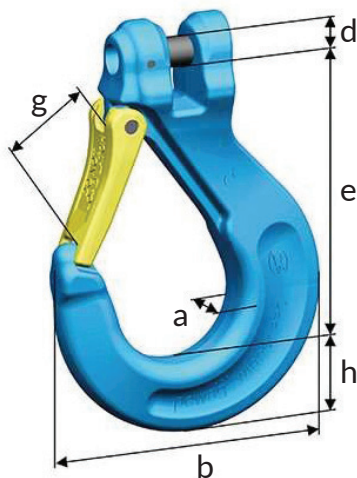

Typ	DOR [kg]	e [mm]	h [mm]	a [mm]	d [mm]	g1 [mm]	b [mm]	Masa [kg/szt.]
KHSWP 7	2360	105	26	19	9,5	36	101	0,84
KHSWP 8	3000	105	26	19	10,7	36	101	0,84
KHSWP 10	5000	121	33	26	14	41	118	1,51
KHSWP 13	8000	148	43	30	17,5	49	147	2,85

HAK BEZPIECZNY WIDEŁKOWY LHWP

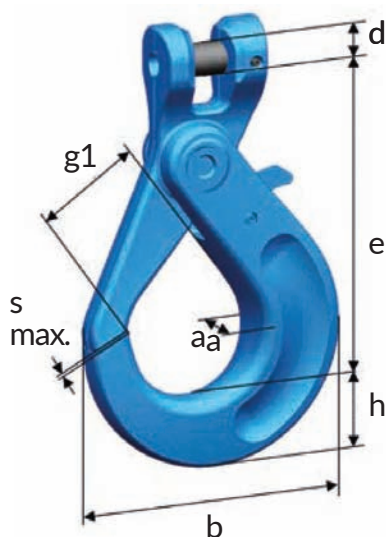

Typ	DOR [kg]	e [mm]	h [mm]	a [mm]	b [mm]	d1 [mm]	d2 [mm]	g [mm]	s max [mm]	Masa [kg/szt.]
LHWP 7/8	3.000	126	25	24	89	25	14	34	1	0,90
LHWP 10	5.000	158	31	28	112	31	17	45	2	1,60
LHWP 13	8.000	205	41	34	145	40	22	54	2	3,30

HAK BEZPIECZNY KLHWP

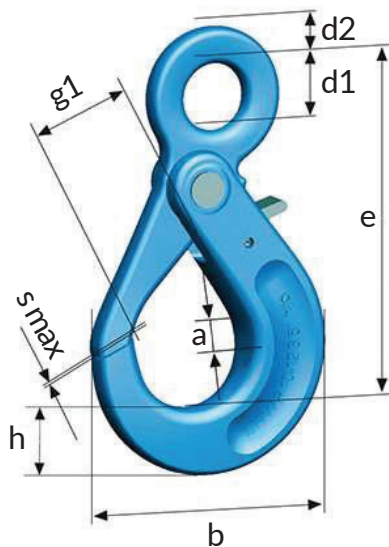

Typ	DOR [kg]	e [mm]	h [mm]	a [mm]	b [mm]	d [mm]	g [mm]	s max [mm]	Masa [kg/szt.]
KLHWP 7	2,360	116	24,50	23,60	90	9,50	32	1	0,89
KLHWP 8	3.000	115	24,50	23,60	90	10,70	32	1	0,9
KLHWP 10	5.000	136	31,50	27,80	113	14	45	1	1,6
KLHWP 13	8.000	179	39,80	33,70	146	17,50	54	1,5	3,42

NAPINACZ ŁAŃCUCHOWY RSWP

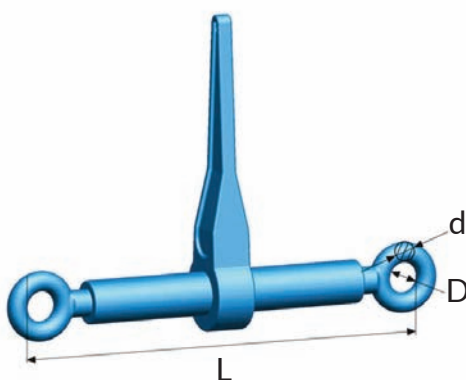

Typ	LC Zdolność mocowania [kN]	STF Siła nominalnego napięcia [daN]	Długość L (zamknięte) [mm]	Długość L (otwarte) [mm]	Długość ramienia l [mm]	D [mm]	D [mm]	Masa [kg/szt.]
RSWP 7/8	60	1,900	355	500	237	20	16	3,20
RSWP 10	100	3,000	565	510	355	26	18	3,80
RSWP 13	160	2,500	576	866	359	31	22	9,00

NAPINACZ ŁAŃCUCHOWY RSKWP

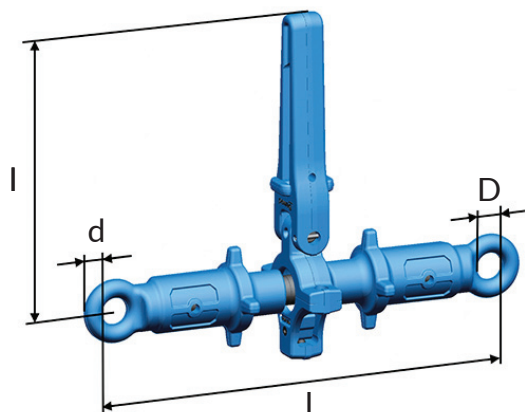

Typ	LC Zdolność mocowania [kN]	STF Siła nominalnego napięcia [daN]	Długość L (zamknięte) [mm]	Długość L (otwarte) [mm]	Długość ramienia l [mm]	D [mm]	D [mm]	Masa [kg/szt.]
RSKWP 7/8	60	2,200	536	176	360	237	23	16
RSKWP 10	100	2,500	536	176	360	360	23	16

NAPINACZ ŁAŃCUCHOWY RSPSWP

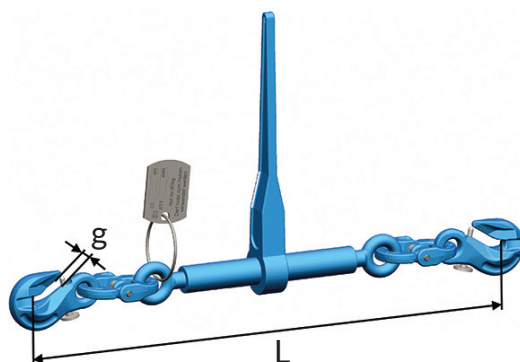

Typ	LC Zdolność mocowania [kN]	STF Siła nominalnego napięcia [daN]	Długość L (zamknięte) [mm]	Długość L (otwarte) [mm]	Długość rami- enia l [mm]	g [mm]	Masa [kg/szt.]
RSPSWP 13	160	2,500	981	1278	17	359	15,7
RSPSWP 8	60	1,900	600	755	10	237	4,90
RSPSWP 10	100	3,000	674	829	13	355	6,70
RSPSWP 7	47	1,900	586	741	10	237	4,60

AKCESORIA ZAWIESIOWE NIERDZEWNE



- Spełniają wymagania dyrektywy maszynowej 2006/42/WE
- Współczynnik bezpieczeństwa: 4
- Użyte materiały: stal w klasie 6 (wytrzymałość na rozciąganie 600 N/mm²)
- Produkty oparte są na materiale 1.4571 (AISI 316 Ti) oraz 1.4404 (AISI 316L) i 1.4462 (AISI 318 LN) ze zredukowaną zawartością węgla
- Odpowiedni dobór gatunków stali pozwolił na uzyskanie komponentów, które mogą pracować w agresywnym środowisku
- Znakowanie: udźwignięcie, znak CE, rozmiar, klasa wytrzymałości, symbol producenta
- Dokumenty: deklaracja zgodności, świadectwo jakości 2.1, instrukcja użytkowania

OGNIWO AWI

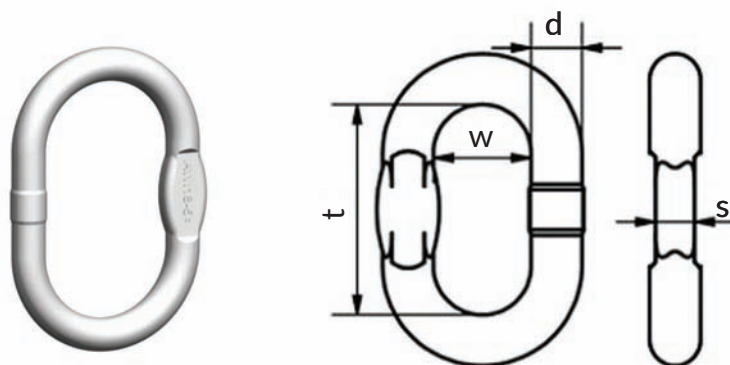

Typ	DOR przy kącie 0-45° [kg]	Stosować do haka wg DIN 15401 numer:	d [mm]	t [mm]	w [mm]	s [mm]	Masa [kg/szt.]	Do 1-cięgowych zawiesi łańcuchowych	Do 2- cięgowych zawiesi łańcuchowych
AWI 8-6	560	0,5	8	60	35	-	0,08	4	4
AWI 10-6	850	1,6	10	80	50	-	0,14	5	5
AWI 13-6	1.600	2,5	13	110	60	10	0,34	6/7/8	6
AWI 16-6	2.600	2,5	16	110	60	14	0,53	10	7/8
AWI 18-6	3.500	5	18	135	75	14	0,92	-	10
AWI 22-6	6.300	6	23	160	90	17	1,60	13/16	13
AWI 26-6	8.900	8	27	180	100	20	2,46	20	16
AWI 32-6	13.200	10	32	200	110	26	4,14	-	20
AWI 36-6	14.700	16	36	260	140	29	6,22	-	-
AWI 45	12.000		45	340	180	**	12,82	26	-

OGNIWO PRZEJŚCIOWE BWI

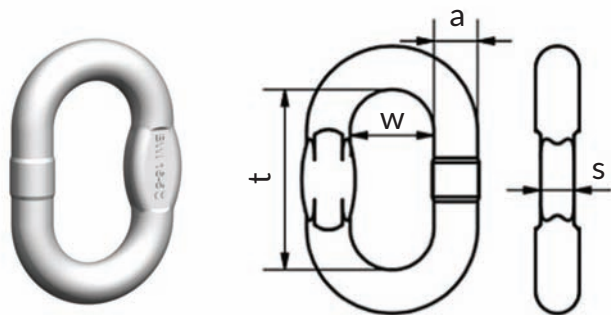

Typ	DOR przy kącie 0-45° [kg]	d [mm]	t [mm]	w [mm]	s [mm]	Masa [kg/szt.]	Do 1-cięgnowych zawiesi łańcuchowych	Do 2-cięgnowych zawiesi łańcuchowych
BWI 7-6	0,9	7	36	16	-	0,03	5/6	5/6
BWI 9-6	1,25	9	44	20	-	0,07	7	7
BWI 10-6	1,6	10	44	20	-	0,09	8	8
BWI 13-6	2,5	13	54	25	10	0,19	10	10
BWI 16-6	4,25	16	70	34	14	0,36	13	13
BWI 20-6	6,3	20	85	40	16	0,71	16	16
BWI 22-6	8,0	23	115	50	17	1,16	20	-
BWI 26-6	10,07	27	140	65	20	1,92	-	-
BWI 32-6	12,0	32	150	70	26	3,18	26	-

OGNIWO ZBIORCZE VWI

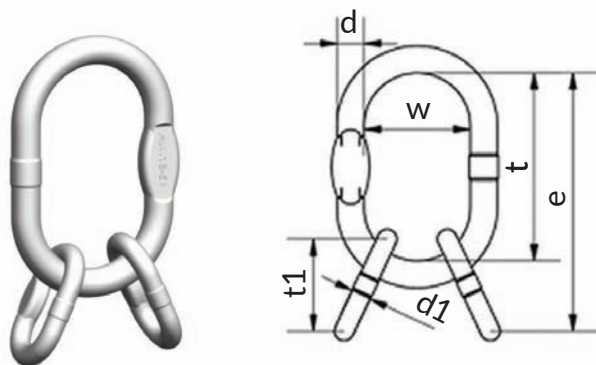

Typ	Składa się z:	Stosować do haka wg DIN 15401 numer:	DOR przy kącie 0-45° [kg]	e (t+t1) [mm]	d [mm]	t [mm]	w [mm]	d1 [mm]	t1 [mm]	w1 [mm]	Masa [kg/szt.]
VWI 4-6	AWI 10-6 + 2 BWI 9-6	1,6	840	124	10	80	50	8	44	20	0,28
VWI 5-6	AWI 13-6 + 2 BWI 10-6	2,5	1.300	154	13	110	60	10	44	20	0,52
VWI 6/7-6	AWI 16-6 + 2 BWI 13-6	5	2.600	164	16	110	60	13	54	25	0,91
VWI 8-6	AWI 18-6 + 2 BWI 16-6	6	3.350	205	18	135	75	16	70	34	1,64
VWI 10-6	AWI 22-6 + 2 BWI 20-6	8	5.250	245	23	160	90	20	85	40	3,02
VWI 13-6	AWI 26-6 + 2 BWI 22-6	10	8.900	295	27	180	100	23	115	50	4,78
VWI 16-6	AWI 32-6 + 2 BWI 26-6	16	13.200	340	32	200	110	27	140	65	7,98

ZŁĄCZKA ŁAŃCUCHOWA CONNEX CWI

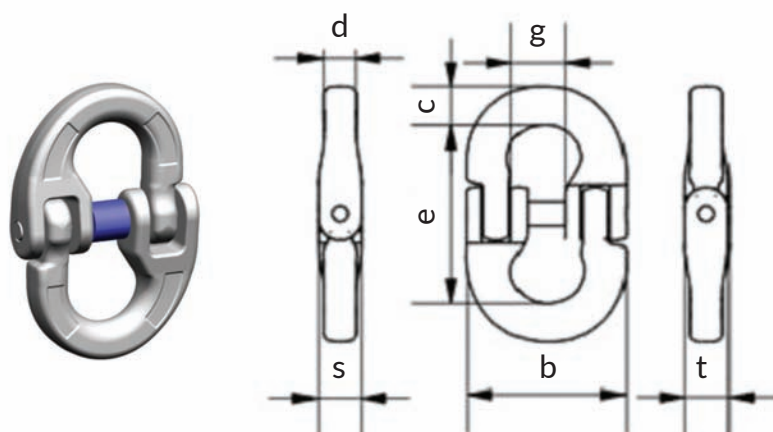

Typ	DOR [t]	e [mm]	c [mm]	s [mm]	t [mm]	d [mm]	b [mm]	g [mm]	Masa [kg/szt.]
CWI 5	0,63	36	7	10	11	7	34	13	0,06
CWI 7	1,25	54	9	13	14	9	51	17	0,14
CWI 10	2,5	73	13	18	18	13	70	25	0,37
CWI 13	4,25	92	17	23	25	17	86	29	0,76
CWI 16	6,3	104	21	32	28	20	105	37	1,41

ŁAŃCUCH WOX

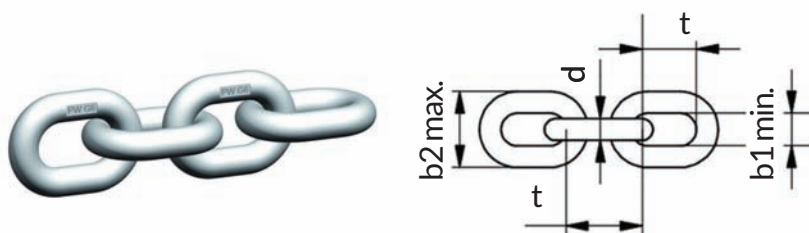

Typ	Średnica łańcucha dn [mm]	Długość łańcucha [m]	Podziałka t [mm]	Szerokość wewnętrzna b1 min. [mm]	Szerokość zewnętrzna b2 max. [mm]	DOR [kg]	Minimalna siła zrywająca [kN]	Masa [kg/m]
WOX 4-6	4	50	12	6,2	14,8	400	16,0	0,38
WOX 5-6	5	50	15	7,5	18,5	630	25,0	0,58
WOX 6-6	6	50	18	8,7	20,9	900	37,5	0,82
WOX 7-6	7	50	21	9,5	25,2	1.250	50,0	1,11
WOX 8-6	8	50	24	10,8	28,6	1.600	63,0	1,43
WOX 10-6	10	50	30	13,5	36,0	2.500	100,0	2,25
WOX 13-6	13	25	39	17,5	46,8	4.250	170,0	3,77
WOX 16-6	16	25	48	21,5	57,6	6.300	250,0	5,62
WOX 20-5	20	-	60	27	72	8.000	314,0	9,29
WOX 26-4+	26	-	78	35,0	93,6	12.000	471,0	16,20

HAK Z UCHEM HSWI

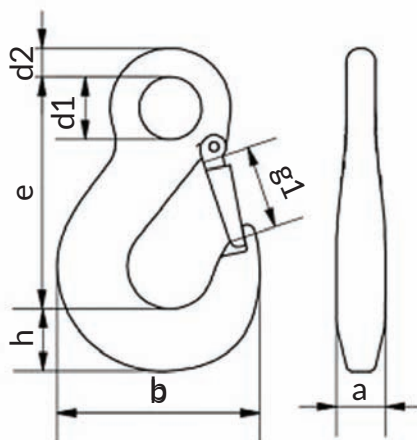

Typ	DOR [t]	e [mm]	h [mm]	a [mm]	d1 [mm]	d2 [mm]	g1 [mm]	b [mm]	Masa [kg/szt.]
HSWI 5/6-6	0,63	84	20	14	21	8	22	67	0,25
HSWI 7/8-6	1,6	112	29	20	27	13	32	98	0,70
HSWI 10-6	2,5	133	33	28	37	15	39	115	1,35
HSWI 13-6	4,25	172	43	35	48	18	51	147	2,60
HSWI 12-6	6,3	213	51	44	55	24	66	182	4,80

SZAKLA SMSWI

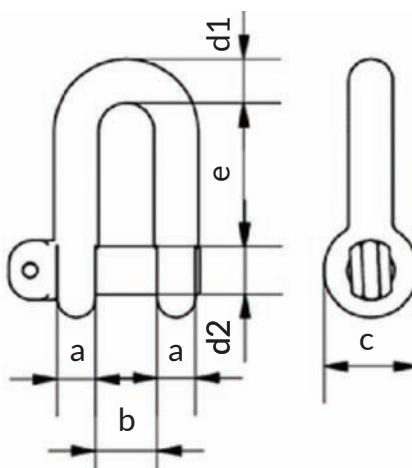

Typ	DOR [t]	e [mm]	a [mm]	b [mm]	d [mm]	d1 [mm]	c [mm]	Masa [kg/szt.]
SMSWI 0,5 t-S	0,5	33	8	18	8	9	18	0,07
SMSWI 1,25 t-S	1,25	40	12	25	12	13	25	0,22
SMSWI 2 t-S	2,0	60	16	32	16	17	32	0,52
SMSWI 3,2 t-S	3,2	78	19	41	19	21	47	0,80
SMSWI 5 t-S	5,0	109	25	56	25	29	60	2,2
SMSWI 26-C	13,0	152	34	76	34	38	75	7,0



SZAKLE

SZAKLA OKRĄGŁA WKRĘCANA KATEGORII 6, TYP „BW” WG. PN-EN 13889

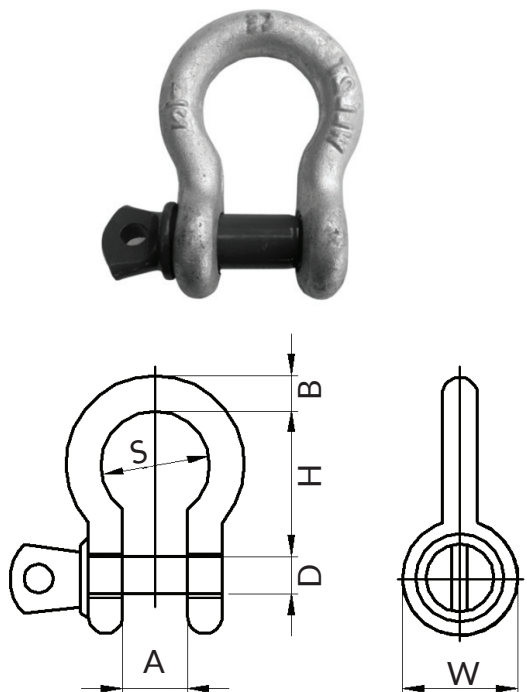

DOR [t]	H [mm]	A [mm]	S [mm]	D [mm]	B [mm]	W [mm]	Masa [kg/szt]
0,5	29	11	19,5	8	7	17,5	0,05
0,75	32	12	20	10	9	20,5	0,1
1	36	15,5	26	11,5	10,5	24,5	0,15
1,5	42	15,5	27,5	12,5	11,5	26,5	0,2
2	48	20	32,5	16	13	31	0,25
3,25	61	26	43	20	17,5	38,5	0,6
4,75	72	31,5	49,5	22,5	21	46	0,95
6,5	85	35	57	25,5	24	52,5	1,5
8,5	96	42,5	67	28,5	27	60,5	2,25
9,5	106	45	72,5	32,5	30	66	3,2
12	118	49,5	81	35	34	74	4,6
13,5	132	56	91	38	35	84,5	6,25
17	147	57	96,5	40,5	39	92	7,95
25	176	68	125	50	45	110	12,75
35	196	79	143	55	52	119	19,4
42,5	217	102	160	65,5	55	134	28
55	260	105	180	71	65	150	36

SZAKLA OKRĄGŁA Z ZABEZPIECZENIEM KATEGORII 6, TYP „BX” WG. PN-EN 13889

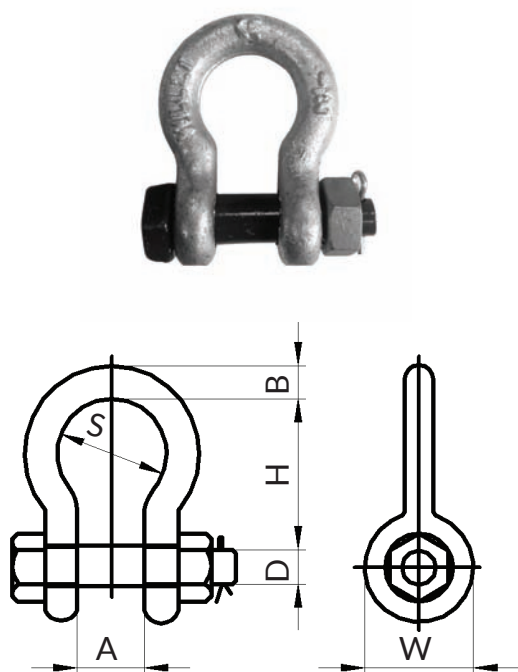

DOR [t]	MBL [kN]	H [mm]	A [mm]	S [mm]	D [mm]	B [mm]	W [mm]	Masa [kg/szt]
0,5	29,4	29	11	19,5	8	7	17,5	0,05
0,75	44,1	30	13	20	10	9	20	0,10
1,0	58,8	36	15	25	12	10,5	24,5	0,15
1,5	88,3	42	18	27	12,5	12	27,5	0,25
2,0	117,7	49,5	20	32,5	16	13	31	0,35
3,25	191,2	58,5	27	42	20	17,5	41	0,75
4,75	279,5	70	32,5	49,5	22	20,5	48,5	1,10
6,5	382,5	86	37	57	27	22,5	52	1,60
8,5	500,1	94,5	42	67	30	27	60,5	2,50
9,5	559,0	108	45	72	33	31	68	3,70
12,0	706,1	120	52,5	82	36	34	76,5	5,10
13,5	794,3	134	56	92,5	39	35	83,5	6,00
17,0	1000,3	147	62	96,5	42	40,5	93	8,65
25,0	1471,0	176	71	125	52	45	110	14,0
35,0	2059,4	196	81	143	60	52	119	21,0
42,5	2500,7	217	102	160	65,5	55	134	31,5
55,0	3236,2	260	105	180	71	65	150	39,0
85,0	5001,4	315	135	200	85	77	163	64,0
120,0	4706,7	365	135	230	105	91	210	111,0
150,0	5885,0	360	145	255	107	116	220	138,0

SZAKLA PODŁUŻNA WKRĘCANE KATEGORII 6, TYP „DW” WG. PN-EN 13889

DOR [t]	H [mm]	A [mm]	D [mm]	B [mm]	W [mm]	Masa [kg/szt]
0,33	20	9	6	5	12,5	0,02
0,5	22	12	8	7	17	0,05
0,75	27	13,5	10	9	21	0,09
1	31	17	11	10	23	0,14
1,5	37	19	13	11	26	0,19
2	43	22	16	13,5	34	0,39
3,25	51	27	20	16	40	0,67
4,75	59	31	22	19	47	1,08
6,5	73	36	25	22	53	1,66
8,5	85	43	28	25	60	2,46
9,5	90	47	32	28	67	3,4
12	94	51	35	32	74	4,51
13,5	115	57	38	35	80	6,1
17	127	60	42	38	89	7,63
25	149	74	50	45	114	13,25
35	171	83	57	50	119	18,53
42,5	290	95	65	57	134	25,94
55	203	105	70	65	145	35,33

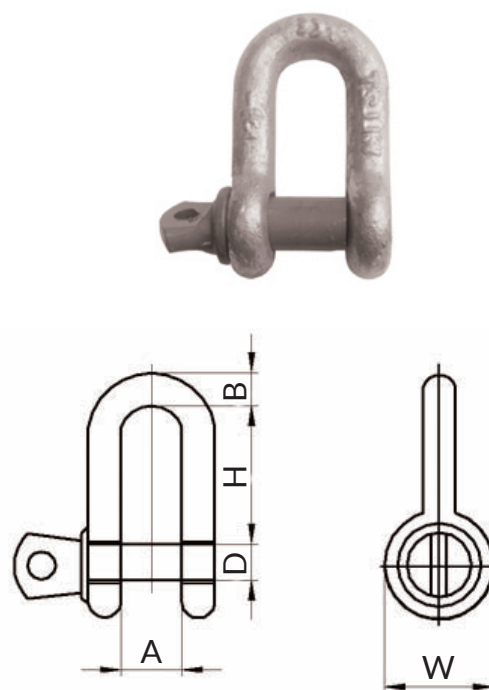

SZAKLA PODŁUŻNA Z ZABEZPIECZENIEM KATEGORII 6, TYP „DX” WG. PN-EN 13889

DOR [t]	H [mm]	A [mm]	D [mm]	B [mm]	W [mm]	Masa [kg/szt]
2	43	22	16	13,5	34	0,39
3,25	51	27	19	16	40	0,67
4,75	59	31	22	19	47	1,08
6,5	73	36	25	22	53	1,66
8,5	85	43	28	25	60	2,46
9,5	90	47	32	28	67	3,4
12	94	51	35	32	74	4,51
13,5	115	57	38	35	80	6,1
17	127	60	42	38	89	7,63
25	149	74	50	45	114	13,25
35	171	83	57	50	119	18,53
42,5	290	95	65	57	134	25,94
55	203	105	70	65	145	35,33
85	229	127	83	75	163	52,97

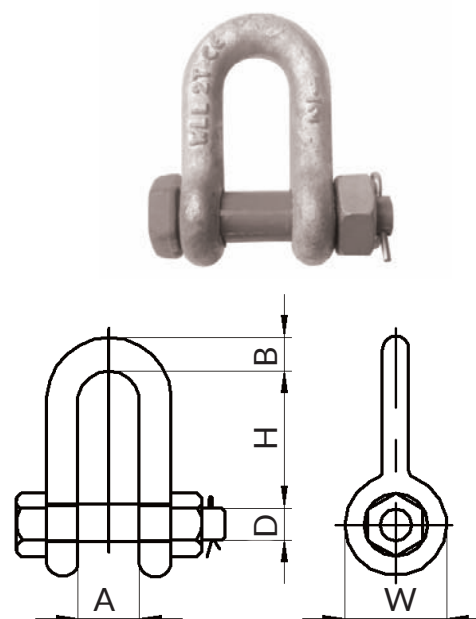

SZAKLA PODŁUŻNA WKRĘCANA TYP „A” WG. DIN 82101

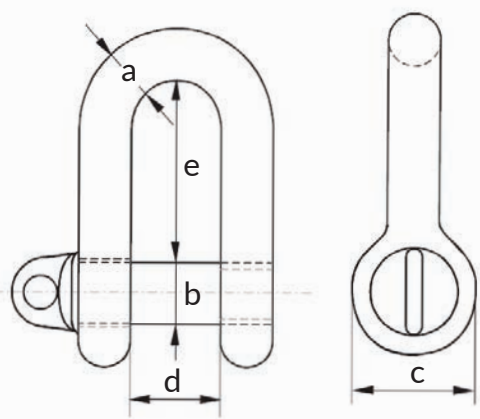

DOR [t]	Średnica łuku a [mm]	Średnica sworznia b [mm]	Średnica oka c [mm]	Szerokość wewnętrzna d [mm]	Długość wewnętrzna e [mm]	Masa [kg/szt]
100	5	5~	10	7	15,5	0,02
160	6	6	12	8	18	0,02
250	8	8	16	11	24	0,05
400	10	10	20	14	30	0,1
600	12	12	24	17	36	0,18
1000	13	16	32	21	49	0,3
1600	16	20	40	27	61	0,57
2000	20	22	44	30	67	0,98
2500	22	24	48	33	73	1,3
3000	25	27	54	38	83,5	1,85
4000	28	30	60	42	91	2,53
5000	32	36	72	47	111	4
6300	36	39	78	53	119,5	5,3
8000	41	45	98	60	139,5	7,9
10000	44	48	9+6	66	147	10
12000	49	52	104	73	158	13,5
16000	55	60	120	81	185	19,2
20000	61	68	136	90	211	28
25000	67	72	144	100	221	34

SZAKLA PODŁUŻNA Z ZABEZPIECZENIEM TYP „C” WG. DIN 82101

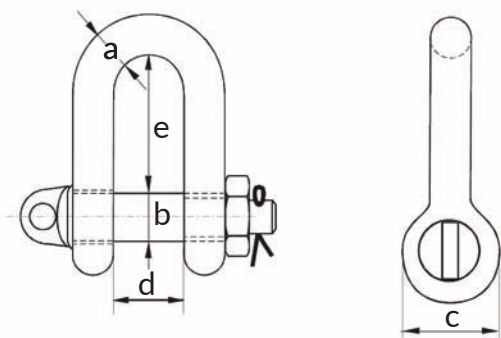

DOR [t]	Średnica łuku a [mm]	Średnica sworznia b [mm]	Średnica oka c [mm]	Szerokość wewnętrzna d [mm]	Długość wewnętrzna e [mm]	Masa [kg/szt]
400	10	10	20	14	30	0,1
630	12	12	24	17	36	0,2
1000	13	16	32	21	49	0,37
1600	16	20	40	27	61	0,69
2000	20	22	44	30	67	1,13
2500	22	24	48	33	73	1,5
3000	25	27	54	38	83,5	2,15
4000	28	30	60	42	91	2,93
5000	32	36	72	47	111	4,7
6300	36	39	78	53	119,5	6,33
8000	41	45	98	60	139,5	8,6
10000	44	48	9+6	66	147	10,8
12000	49	52	104	73	158	14,4
16000	55	60	120	81	185	20,5
20000	61	68	136	90	211	10
25000	67	72	144	100	221	36

SZAKLA OKRĄGŁA KATEGORII 8 Z ZABEZPIECZENIEM TYPU SZEROKIEGO

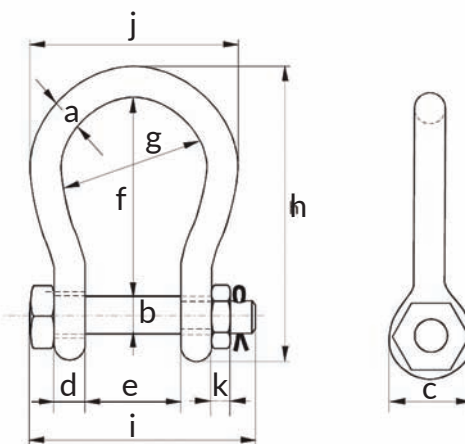
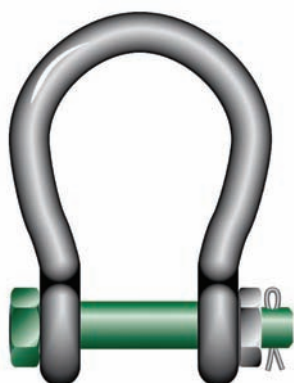

DOR [kg]	Średnica łuku a [mm]	Średnica sworznia b [mm]	Średnica oka c [mm]	Szerokość oka d [mm]	Szerokość Wewnętrzna e [mm]	Długość wewnętrzna f [mm]	Szerokość łuku g [mm]	Długość h [mm]	Długość sworznia i [mm]	Szerokość j [mm]	Grubość nakrętki k [mm]	Masa [kg/szt.]
4750	22	25	52	22	63	112	88	173	157	132	22	2.08
6500	25	28	59	25	75	135	105	204	183	155	25	3.14
8500	28	32	66	28	82	148	115	225	205	171	27	4.36
9500	32	35	72	32	90	162	126	248	224	190	30	5.95
12000	35	38	79	35	100	180	140	274	245	210	33	7.87
16000	38	42	88	38	106	216	159	319	248	235	19	12.5
25000	45	50	103	45	127	248	175	370	296	265	23	16.7
30000	50	57	118	50	146	273	207	411	332	307	26	25
55000	65	70	145	65	165	314	213	487	391	343	32	45
75000	83	83	164	83	184	330	254	537	460	420	39	70

SZAKLA SZEROKA

DOR [t]	a [mm]	b [mm]	c [mm]	d [mm]	e [mm]	f [mm]	g [mm]	h [mm]	i [mm]	Waga [kg]
4.6	19	22	46	19	70	116	169	154	19	1.5
8.6	25	28	59	25	83	140	208	190	25	3.15
15.5	38	42	88	38	115	178	281	257	18.5	9

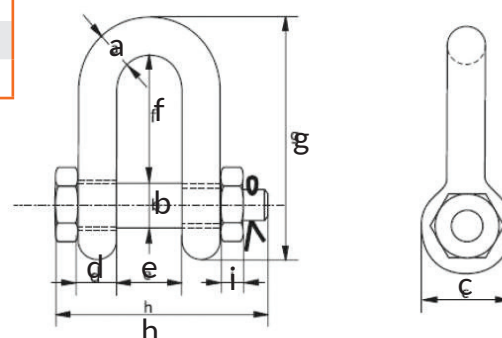

SZAKLA OKRĄGŁA KATEGORII 8 Z ZABEZPIECZENIEM

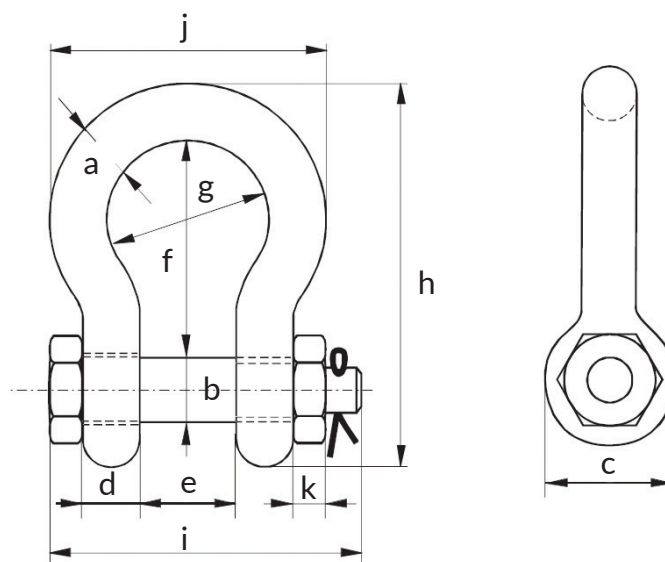
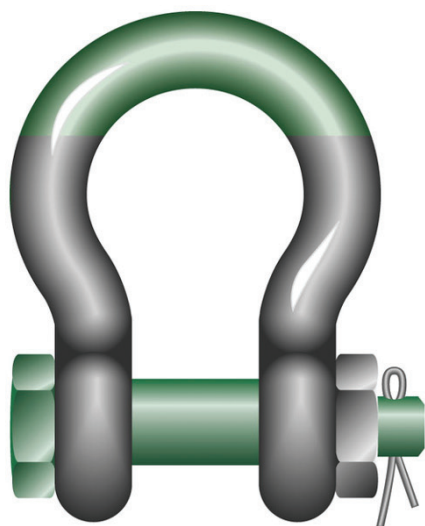

DOR [kg]	Średnica kabłąka a [mm]	Średnica sworznia b [mm]	Średnica oka c [mm]	Szerokość oka d [mm]	Szerokość wewnętrzna e [mm]	Długość wewnętrzna f [mm]	Szerokość łuku g [mm]	Długość h [mm]	Długość sworznia i [mm]	Szerokość j [mm]	Grubość nakrętki k [mm]	Masa [kg/szt.]
3300	13.5	16	34	13	22	51	32	89	82	58	13	0.40
5000	16	19	40	16	27	64	43	110	98	75	17	0.73
7000	19	22	46	19	31	76	51	129	114	89	19	1.18
9500	22	25	52	22	36	83	58	144	130	102	22	1.73
12500	25	28	59	25	43	95	68	164	150	118	25	2.56
15000	28	32	66	28	47	108	75	185	166	131	27	3.6
18000	32	35	72	32	51	115	83	201	178	147	30	4.95
21000	35	38	80	35	57	133	92	227	197	162	33	6.62
30000	38	42	88	38	60	146	99	249	217	175	34	8.11
40000	45	50	103	45	74	178	126	300	260	216	40	15
55000	57	57	117	57	83	197	138	341	303	252	46	23
85000	70	70	143	70	105	260	180	427	262	320	56	44
120000	83	83	162	83	127	329	190	535	425	356	66	71

SZAKLA OKRĄGŁA KATEGORII 8 Z ZABEZPIECZENIEM

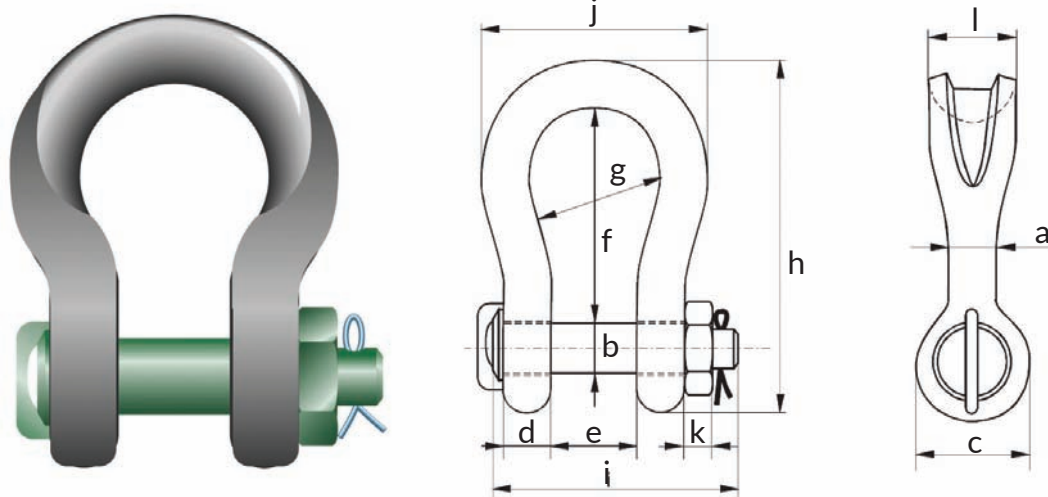

DOR [kg]	Średnica kabłąka a [mm]	Średnica sworznia b [mm]	Średnica oka c [mm]	Szerokość oka d [mm]	Szerokość Wewnętrzna e [mm]	Długość wewnętrzna f [mm]	Szerokość łuku g [mm]	Długość h [mm]	Długość kabłąka i [mm]	Szerokość j [mm]	Grubość nakrętki k [mm]	Pow. nośna l [mm]	Masa [kg/szt.]
7000	22	22	46	19	32	96	64	153	115	110	19	41	2
12500	28	28	61	25	44	121	82	197	151	146	24	54	4
18000	35	35	69	30	54	148	102	239	175	180	29	64	7
30000	40	42	90	35	69	165	126	279	211	200	34	79	13
40000	55	51	109	45	84	199	140	331	252	235	38	97	21
55000	60	57	115	55	90	240	160	389	299	270	45	100	30
75000	68	70	125	54	110	290	185	473	327	317	54	120	48
125000	85	80	154	85	137	366	220	583	426	390	64	150	92
150000	94	95	179	89	147	391	253	645	435	434	50	170	140
200000	110	105	199	100	158	481	280	759	470	482	50	205	205
250000	126	120	227	110	179	542	300	859	519	530	60	240	264
300000	135	134	245	122	195	601	350	947	575	620	70	265	360
400000	160	160	293	145	231	576	370	985	675	690	80	320	580
500000	170	180	328	160	263	681	450	1131	748	790	90	339	780
600000	190	200	348	170	289	741	490	1234	809	865	100	370	980
700000	200	215	392	190	315	751	540	1284	879	901	100	400	1360

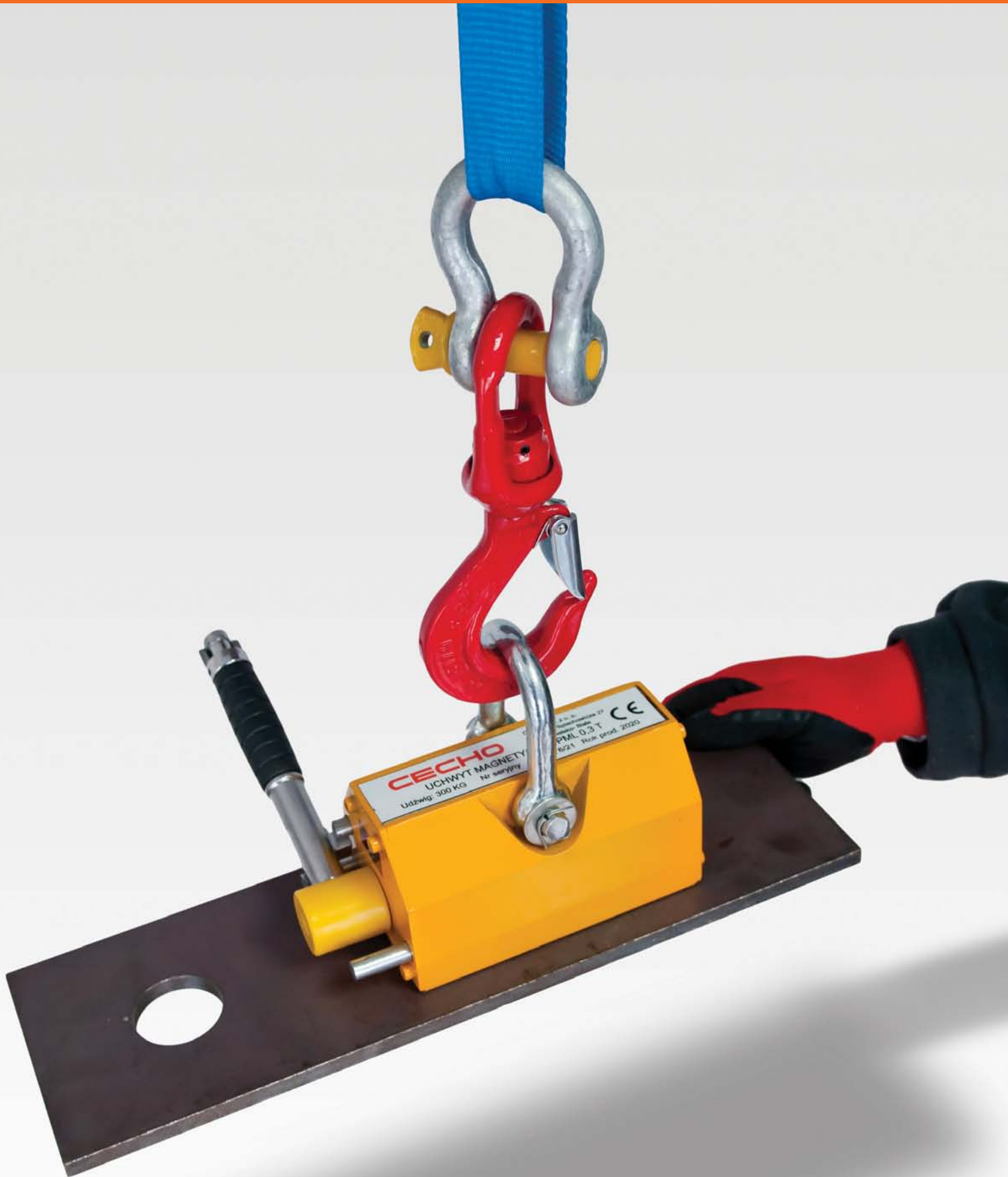

POZOSTAŁE AKCESORIA ZAWIESIOWE

KAUSZA

Rozmiar średnica liny [mm]	D [mm]	A [mm]	C [mm]	F [mm]	K [mm]	Masa [kg/szt.]
8	45	20,5	13	9	4	0,06
10	58	26,5	16	12	5	0,10
12	66	32	19,5	16	6	0,15
14	72	38	20	17	7	0,25
16	73	41	24	19	9	0,35
18	85	46	25,5	21	9	0,45
20	106	52	29,5	24	10	0,50
22	119	59	32	26,5	11	0,75
24	124	63	34	28	11	0,95
26	146	69	38	31	12	1,45
28	147	74	39	32	12	1,65
32	170	84	47	37	15	2,55
36	200	87	53	41	15	3,25
40	208	100	65	56	17	4,50
44	230	116	61	52	17	5,35
48	245	124	66	61	19	6,45
52	270	129	69	63	20	6,55
56	300	140	82	68	22	11,55

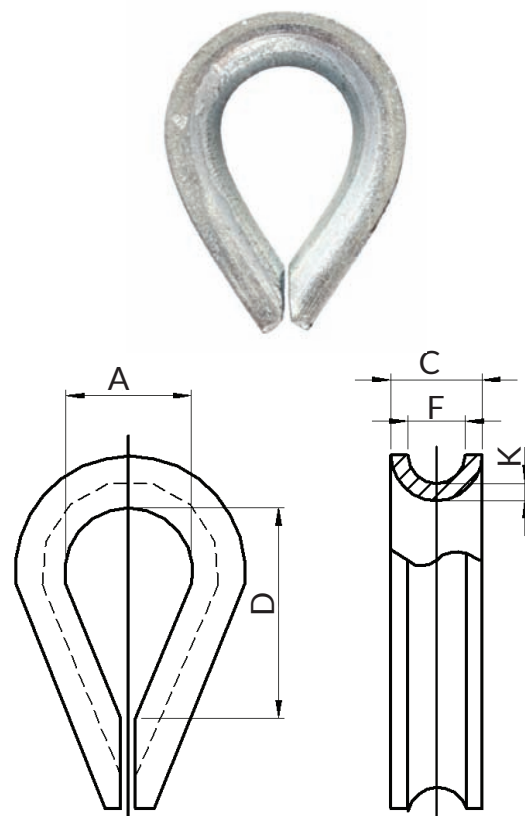

KAUSZA PEŁNA

Rozmiar średnica liny [mm]	L [mm]	A* min/max [mm]	B [mm]	C [mm]	F [mm]	Masa [kg/szt.]
8	66	14/20	40	15	9	0,16
10	83	18/25	50	17,5	11,5	0,28
12	100	21/30	60	20	14	0,43
14	115	25/35	70	23,5	16,5	0,75
16	131	28,5/40	80	26	18,5	0,80
18	146	31,5/45	92	30	21	1,20
20	163	35/50	102	31	22	1,50
22	180	38/55	110	34	25	1,80
24	194	41/60	120	35,5	27	2,45
26	210	43/64	130	40	29,5	3,15
28	225	47/70	140	42,5	31	3,90
32	258	53/80	160	47	36	5,40
36	290	60/90	180	54,5	42	7,80
40	323	66/100	200	58	45	10,0
44	355	70/110	220	63	50	13,3

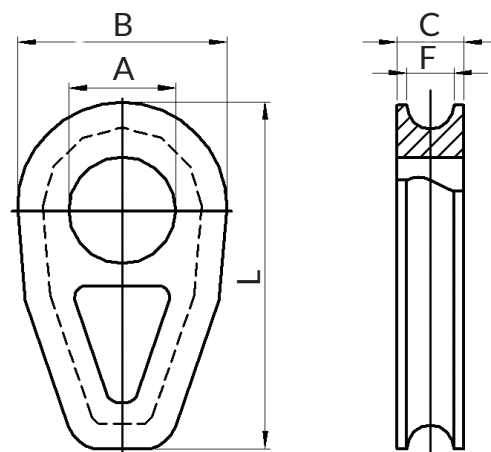

*Występuje możliwość rozwiercenia otworu

ZACISK KABŁĄKOWY WZMOCNIONY

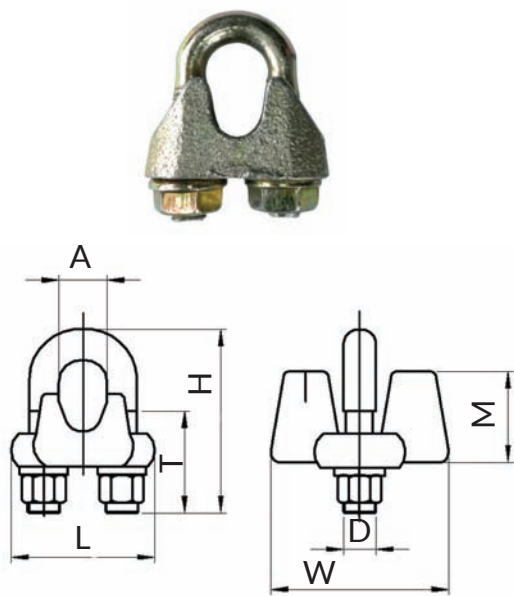

Rozmiar	Zalecana średnica liny [mm]	Min. ilość zacisków na pętli [szt]	D [mm]	H [mm]	A [mm]	T [mm]	L [mm]	W [mm]	M [mm]	Masa kg/100szt
5	3,0 ÷ 5,0	3	M5	25	7	14	25	13	13	2,0
6,5	5,0 ÷ 6,5	3	M6	32	8	17	30	16	14	4,0
8	6,5 ÷ 8,0	4	M8	41	10	20	39	20	18	8,2
10	8,0 ÷ 10,0	4	M8	46	12	24	40	20	21	9,2
12	10,0 ÷ 12,0	4	M10	56	14	28	50	25	24	21,5
14	12,0 ÷ 14,0	4	M12	66	16	31	59	30	28	39,5
16	14,0 ÷ 16,0	4	M14	76	20	35	64	32	35	43,0
19	16,0 ÷ 19,0	5	M14	83	23	36	68	33	40	49,0
22	19,0 ÷ 22,0	5	M16	96	25	40	74	34	44	68,0
26	22,0 ÷ 26,0	5	M20	111	26	50	84	38	51	117,0
30	26,0 ÷ 30,0	6	M20	127	34	55	95	41	59	140,0
34	30,0 ÷ 34,0	6	M22	141	38	60	105	45	67	213,0
40	34,0 ÷ 40,0	6	M24	159	44	65	117	49	77	268,0

ZACISK ALUMINIOWY DO LIN STALOWYCH

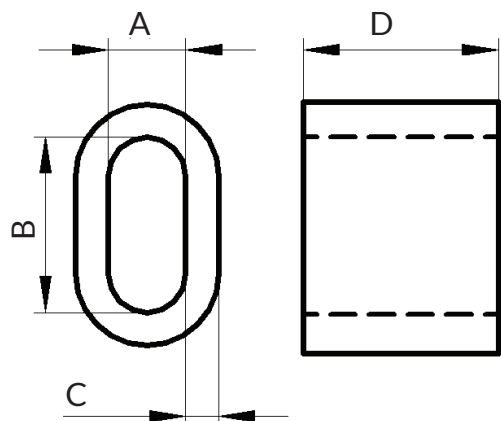

Rozmiar - średnica liny [mm]	D [mm]	C [mm]	A [mm]	B [mm]	Masa kg/1000szt
1	5	0,65	1,2	2,4	0,1
1,5	6	0,75	1,7	3,4	0,21
2	7	0,85	2,2	4,4	0,24
2,5	9	1,05	2,7	5,4	0,5
3	11	1,25	3,3	6,6	0,84
3,5	13	1,5	3,8	7,6	1,32
4	14	1,7	4,4	8,8	1,81
5	18	2,1	5,5	11	3,57
6	21	2,5	6,6	13,2	5,86
6,5	23	2,7	7,2	14,4	7,55
8	28	3,3	8,8	17,6	13,7
10	35	4,1	10,9	21,8	26,4
11	39	4,5	12,1	24,2	35,8
12	42	4,9	13,2	26,4	45,8
13	46	5,4	14,2	28,4	59,7
14	49	5,8	15,3	30,6	73,5
16	56	6,7	17,5	35	111
18	63	7,6	19,6	39,2	159
20	70	8,4	21,7	43,4	217
22	77	9,2	24,3	48,6	292
24	84	10	26,4	52,8	376
26	91	10,9	28,5	57	481
28	98	11,7	31	62	603
30	105	12,5	33,1	66,2	739
32	112	13,4	35,2	70,4	897
34	119	14,2	37,8	75,6	1080
36	126	15	39,8	79,6	1275
38	133	15,8	41,9	83,8	1490
40	140	16,6	44	88	1734
42	147	17,5	46,2	92,4	2020

ŚRUBA RZYMSKA OCYNKOWANA HAK/HAK

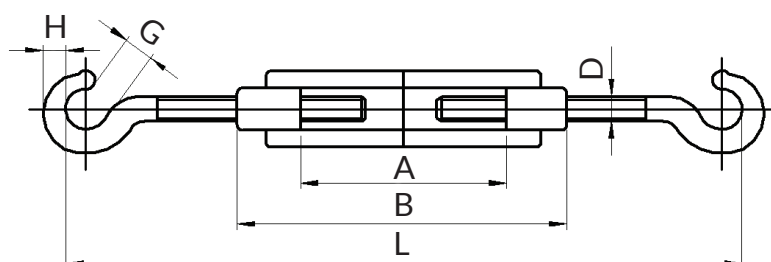

Rozmiar D [mm]	DOR [t]	MBL [kN]	Wymiary [mm]						Masa [kg/szt.]
			A	B	G	H	L _{max}	L _{min}	
6 x 102	0,18	8,8	102	123	11,5	12,5	195	285	0,15
8 x 114	0,32	15,7	114	138	12,5	13	220	320	0,25
10 x 152	0,45	22,1	152	180	13,5	14,5	275	415	0,40
12 x 152	0,68	33,3	152	190	18	20	315	455	0,70
16 x 152	1,02	50,0	152	200	21	25	350	490	1,25
20 x 229	1,36	66,7	229	285	25	28	470	690	2,30
25 x 305	2,27	111,3	305	380	32	38	630	920	5,15
32 x 305	2,95	144,6	305	392	42	47	670	975	8,15

ŚRUBA RZYMSKA OCYNKOWANA OKO/OKO

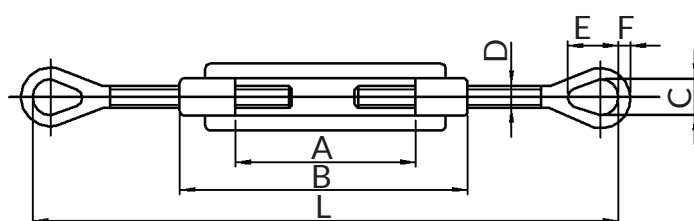

Rozmiar D [mm]	DOR [t]	MBL [kN]	Wymiary [mm]							Masa [kg/szt.]
			A	B	C	E	F	L _{max}	L _{min}	
6 x 102	0,23	11,3	102	123	8,5	19,5	6,5	195	285	0,15
8 x 114	0,36	17,7	114	138	11,5	23	8	220	320	0,25
10 x 152	0,54	26,5	152	180	13,5	28	9	275	415	0,40
12 x 152	1,00	49,0	152	190	18	35,5	12	315	455	0,70
16 x 152	1,59	78,0	152	200	22	44	15	350	490	1,25
20 x 229	2,36	118,0	229	285	25	52	17	470	690	2,30
25 x 305	4,54	222,6	305	380	35	73	24	630	920	5,15
32 x 305	6,91	338,8	305	392	44	90	30	724	1250	8,05

ŚRUBA RZYMSKA OCYNKOWANA SZAKLA/SZAKLA

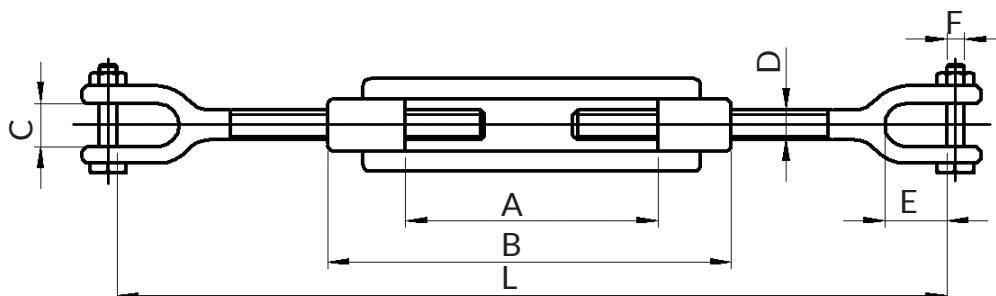

Rozmiar D [mm]	DOR [t]	MBL [kN]	Wymiary [mm]							Masa [kg/szt.]
			A	B	C	E	F	L min	L max	
10 x 152	0,54	26,4	152	180	13	23	8	270	410	0,3
12 x 152	1,00	49,0	152	190	16	27	9,5	300	440	0,7
12 x 229	1,00	49,0	229	265	15	27	10	390	590	0,9
16 x 152	1,59	78,0	152	200	20	34	16	325	470	1,3
16 x 229	1,59	78,0	300	350	20	34	13	415	635	1,6
16 x 300	1,59	78,0	300	350	20	34	13	495	780	1,8
20 x 152	2,36	118,0	152	205	24	38	16	360	500	2,3
20 x 229	2,36	118,0	229	285	24	38	16	470	650	2,3
20 x 300	2,36	118,0	300	360	24	38	16	520	800	2,5
22 x 152	3,27	160,3	152	212	28	42	18,5	400	530	3,1
22 x 229	3,27	160,3	229	290	28	42	18,5	490	700	3,3
22 x 457	3,27	160,3	457	515	28	42	18,5	715	1145	5,0
22 x 152	4,54	222,6	152	220	30	40	22	450	590	4,3
25 x 300	4,54	222,6	300	375	32	50	22	590	850	5,7
25 x 610	4,54	222,6	610	680	32	50	22	890	1480	8,8
32 x 300	6,91	338,8	300	380	45	72	28,5	670	950	8,3
32 x 450	6,91	338,8	450	525	45	72	28,5	800	1240	11,0
32 x 610	6,91	338,8	610	695	45	72	28,5	980	1565	14,0
38 x 305	9,71	476,1	305	400	50	75	36	720	1020	14,6
38 x 457	9,71	476,1	457	540	50	75	36	860	1280	16,7
38 x 610	9,71	476,1	610	705	50	75	36	1020	1600	19,7
44 x 460	12,70	622,9	460	570	56	95	42	945	1360	28,3
44 x 610	12,70	622,9	600	700	60	95	42	1070	1650	30,3
50 x 610	16,78	813,2	610	725	68	110	50	1240	1800	44,0
63 x 610	27,22	1334	610	770	73	127	54	1300	1840	77,1

**ŻYWICA WIRELOCK
DO ZALEWANIA
KOŃCÓWEK
LINOWYCH SOCKET**



**PRZYWIESZKI
DO ZAWIESI
I ODCIĄGÓW
ŁAŃCUCHOWYCH**



**ZESTAWY
NAPRAWCZE DO
RÓŻNYCH HAKÓW
- ZAPADKI**



(w zapytaniu/zamówieniu prosimy podać informację odczytane z haka do którego ma być dobrana zapadka)

KOŃCÓWKA LINOWA DO ZALEWANIA - UCHO

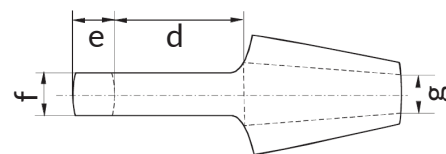
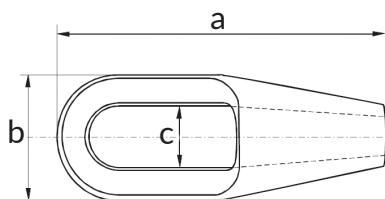

Numer	DOR [kg]	Średnica liny [mm]	Długość a [mm]	Szerokość b [mm]	Szerokość wew. łuku c [mm]	Długość wew. łuku d [mm]	Grubość łuku e [mm]	Grubość łuku f [mm]	Otwór g [mm]	Masa [kg/szt.]
296	8000	6-7	101	37	22	40	11	13	9	0.3
297	12000	8-10	119	43	25	48	14	17.5	12	0.5
298	20000	11-13	140	52	30	58	18	23.5	15	0.75
299	25000	14-16	162	68	37	66	21	26	17.5	1.5
200	40000	18-19	194	76	42	78	27	32	21.5	2.1
201	55000	20-22	224	92	47	90	33	38	24	3.6
204	75000	23-26	253	104	57	103	36	44	28	5.8
207	90000	27-30	282	114	63	116	39	51	32	7
212	125000	31-36	312	127	70	130	43	57	38	10.5
215	150000	37-39	358	136	79	155	51	63	41	13
217	170000	40-42	390	146	83	171	54	70	44	17
219	225000	43-48	443	171	93	198	55	76	51	26
222	280000	49-54	502	193	100	224	62	82	57	37.5
224	360000	55-60	548	216	112	247	73	92	63	50
226	425000	61-68	597	241	140	270	79	102	73	65
227	460000	69-75	644	273	159	286	79	124	79	94
228	560000	76-80	686	292	171	298	83	133	86	115
229	625000	81-86	743	311	184	311	102	146	92	145
230	720000	87-93	788	330	187	330	102	159	99	168
231	875000	94-102	845	362	216	356	108	178	108	210
233	1200000	108-115	1000	405	235	425	125	190	125	330
240	1300000	120-130	1150	450	260	525	125	200	143	500

KOŃCÓWKA LINOWA DO ZALEWANIA - WIDEŁKA

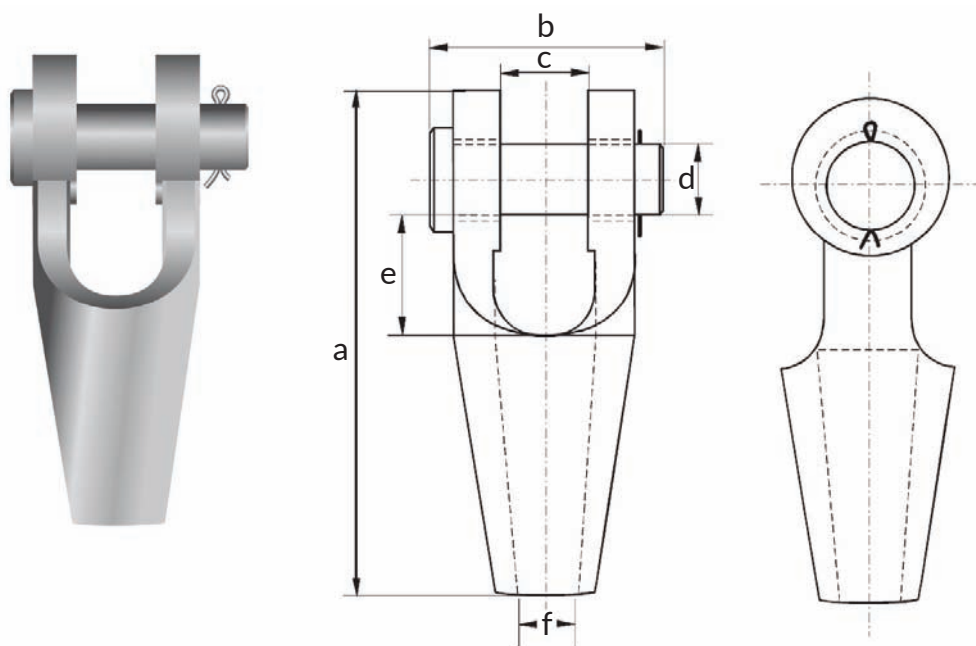





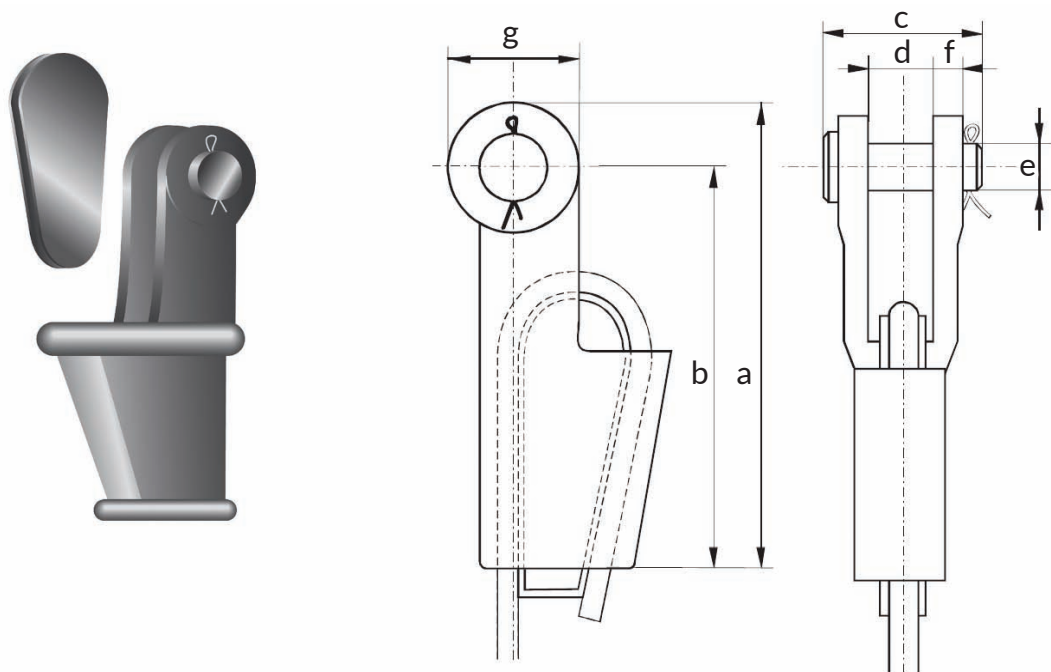









Numer	DOR [kg]	Średnica liny [mm]	Długość a [mm]	Szerokość b [mm]	Szerokość wew. c [mm]	Średnica sworznia d [mm]	Długość wewn. e [mm]	Otwór f [mm]	Masa [kg/szt.]
196	8000	6-7	109	51	19	16	33	9	0.4
197	12000	8-10	124	62	21	21	34	12	0.7
198	20000	11-13	143	66	26	25	37	115	1
199	25000	14-16	172	82	33	30	49	18	1.8
100	40000	18-19	205	95	38	35	58	21	3
104	55000	20-22	235	110	44	41	68	24	4.6
108	75000	23-26	275	130	51	51	75	28	8
111	90000	27-30	306	144	57	57	85	32	11
115	125000	31-36	338	155	63	64	95	38	16
118	150000	37-39	394	178	76	70	127	41	22
120	170000	40-42	418	187	76	76	127	44	27
125	225000	43-48	468	213	89	89	134	51	41
128	280000	49-54	552	240	101	95	191	57	64
130	360000	55-60	598	270	113	108	196	63	88
132	425000	61-68	654	303	127	121	213	73	125
135	460000	69-75	696	349	133	127	216	79	155
138	560000	76-80	737	371	146	133	220	86	187
140	625000	81-86	788	391	159	140	228	92	230
142	720000	87-93	852	411	171	152	242	99	265
144	875000	94-102	914	447	191	178	254	108	400
146	12000000	108-115	1160	489	206	193	369	125	660
150	13000000	120-130	1310	603	225	250	390	143	735

KOŃCÓWKA LINOWA - ZŁĄCZE KLINOWE



Numer	DOR [kg]	Średnica liny [mm]	Długość a [mm]	Długość do środka sworzni b [mm]	Szerokość c [mm]	Szerokość wewn. d [mm]	Średnica sworzni e [mm]	Grubość ramion f [mm]	Średnica oka g [mm]	Masa [kg/szt.]
0.25	8000	7-8	128	110	51	18	16	9	36	0.8
0.5	12000	9-10	165	142	62	20.5	21	11	46	1.5
1	20000	11-13	175	146	66	25	25	12	57	2.4
2	25000	14-16	211	176	82	31	30	15	70	4
3	40000	18-19	252	212	95	38	35	16	80	7.4
4	55000	20-22	288	240	110	44	41	19	95	11
5	75000	23-26	329	274	130	51	51	22	110	16
6	90000	27-29	375	310	144	57	57	25	130	22
7	110000	30-32	423	350	155	63	64	28	146	31
8	125000	34-36	474	400	163	69	64	28	148	39
9	150000	37-39	527	450	178	76	70	30	153	48
10	170000	43-48	580	500	187	76	76	33	160	64
11	225000	43-48	650	550	226	89	89	39	186	96
12	280000	49-52	745	640	240	101	95	46	194	130
13	360000	54-58	660	550	226	89	89	39	186	96
14	425000	60-68	970	835	300	127	121	60	250	275
15	460000	72-76	1150	1000	355	146	133	76	270	440
16	625000	81-86	1252	1100	375	159	140	79	300	510

PUNKTY MOCUJĄCE

Nazwa	Rozmiar	Udźwig [kg]									
											
		0°	90°	0°	90°	0°-45°	45°-60°	0°-45°	45°-60°	0°-45°	0°-45°
PLAW 	M 8	300	300	600	600	400	300	600	400	300	300
	M 10	630	630	1 250	1 250	850	630	1 300	900	630	630
	M 12	1 000	1 000	2 000	2 000	1 400	1 000	2 100	1 500	1 000	1 000
	M 16	1 500	1 500	3 000	3 000	2 100	1 500	3 100	2 200	1 500	1 500
	M 20	2 500	2 500	5 000	5 000	3 500	2 500	5 300	3 700	2 500	2 500
	M 24	4 000	4 000	8 000	8 000	5 600	4 000	8 400	6 000	4 000	4 000
	M 30	6 000	6 000	12 000	12 000	8 500	6 000	12 700	9 000	6 000	6 000
	M 36	7 000	7 000	14 000	14 000	9 800	7 000	14 800	10 400	7 000	7 000
	M 36	8 000	8 000	16 000	16 000	11 300	8 000	16 900	12 000	8 000	8 000
	M 42	10 000	10 000	20 000	20 000	14 000	10 000	21 000	15 000	10 000	10 000
M 42	15 000	15 000	30 000	30 000	21 000	15 000	31 500	22 500	15 000	15 000	
M 48	20 000	20 000	40 000	40 000	28 000	20 000	42 000	30 000	20 000	20 000	
PLBW 	M 8	500	300	1 000	600	400	300	600	450	300	300
	M 10	1 000	600	2 000	1 200	800	600	1 300	900	600	600
	M 12	1 300	1 000	2 600	2 000	1 400	1 000	2 100	1 500	1 000	1 000
	M 14	2 000	1 300	4 000	2 600	1 800	1 300	2 700	1 900	1 300	1 300
	M 16	2 500	1 600	5 000	3 200	2 200	1 600	3 400	2 400	1 600	1 600
	M 18	3 000	2 000	6 000	4 000	2 800	2 000	4 200	3 000	2 000	2 000
	M 20	3 500	2 500	7 000	5 000	3 500	2 500	5 300	3 700	2 500	2 500
	M 22	4 500	3 000	9 000	6 000	4 200	3 000	6 300	4 500	3 000	3 000
	M 24	5 500	4 000	11 000	8 000	5 600	4 000	8 400	6 000	4 000	4 000
	M 27	6 500	5 000	13 000	10 000	7 000	5 000	10 500	7 500	5 000	5 000
M 30	7 000	6 300	14 000	12 600	8 800	6 300	13 200	9 400	6 300	6 300	
M 33	9 000	8 000	18 000	16 000	11 000	8 000	16 500	12 000	8 000	8 000	
M 36	11 000	10 000	22 000	20 000	14 000	10 000	21 000	15 000	10 000	10 000	
M 42	13 500	12 500	27 000	25 000	17 500	12 500	26 300	18 700	12 500	12 500	
M 48	16 000	15 000	32 000	30 000	21 000	15 000	32 000	22 500	15 000	15 000	
PLGW 	M 8	1 000	300	2 000	600	400	300	600	400	300	300
	M 10	1 500	500	3 000	1 000	700	500	1 000	700	500	500
	M 12	2 000	700	4 000	1 400	1 000	700	1 400	1 000	700	700
	M 16	4 000	1 500	8 000	3 000	2 100	1 500	3 000	2 200	1 500	1 500
	M 20	5 000	2 300	10 000	4 600	3 200	2 300	4 800	3 400	2 300	2 300
	M 24	6 500	3 200	13 000	6 400	4 500	3 200	6 700	4 800	3 200	3 200
	M 30	12 000	4 000	24 000	8 000	5 600	4 000	8 200	6 000	4 000	4 000
	M 36	15 000	7 000	30 000	14 000	9 800	7 000	14 700	10 500	7 000	7 000
M 42	22 000	9 000	44 000	18 000	12 600	9 000	18 900	13 500	9 000	9 000	
M 48	30 000	12 000	60 000	24 000	16 800	12 000	25 000	18 000	12 000	12 000	
AOR 	M 16	3 150	3 150	6 300	6 300	4 250	3 150	6 700	4 750	3 150	3 150
	M 20	5 300	5 300	10 600	10 600	7 500	5 300	11 200	8 000	5 300	5 300
	M 30	8 000	8 000	16 000	16 000	11 200	8 000	17 000	11 800	8 000	8 000
	M 36	15 000	15 000	30 000	30 000	21 200	15 000	31 500	22 400	15 000	15 000
	M 42	21 200	21 200	42 400	42 400	30 000	21 200	45 000	31 500	21 200	21 200
	M 45	25 000	25 000	50 000	50 000	33 500	25 000	50 000	37 500	25 000	25 000
M 56	31 500	31 500	63 000	63 000	45 000	31 500	67 000	47 500	31 500	31 500	
M 56	36 000	36 000	72 000	72 000	50 000	36 000	75 000	53 000	36 000	36 000	

Udźwig [kg]

Nazwa	Rozmiar	Udźwig [kg]									
		0°	90°	0°	90°	0°-45°	45°-60°	0°-45°	45°-60°	0°-45°	0°-45°
CAW	6	1 120	1 120	2 240	2 240	1 600	1 120	2 360	1 700	1 120	1 120
	8	2 000	2 000	4 000	4 000	2 800	2 000	4 250	3 000	2 000	2 000
	10	3 150	3 150	6 300	6 300	4 250	3 150	6 700	4 750	3 150	3 150
	13	5 300	5 300	10 600	10 600	7 500	5 300	11 200	8 000	5 300	5 300
	16	8 000	8 000	16 000	16 000	11 200	8 000	17 000	11 800	8 000	8 000
	22	15 000	15 000	30 000	30 000	21 200	15 000	31 500	22 400	15 000	15 000
CAT	M 8	600	300	1200	600	420	300	630	450	300	300
	M 10	1000	500	2000	1000	750	500	1100	750	500	500
	M 12	1000	500	2000	1000	750	500	1100	750	500	500
	M 16	2000	1120	4000	2000	1500	1120	2360	1600	1120	1120
	M 20	4000	2000	8000	4000	2800	2000	4000	3000	2000	2000
	M 24	6300	3150	12500	6300	4250	3150	6300	4750	3150	3150
	M 30	10600	5300	21200	10600	7100	5300	11200	8000	5300	5300
	M 30 D	12500	8000	25000	16000	11200	8000	16800	12000	8000	8000
	M 36	12500	8000	25000	16000	11200	8000	16800	12000	8000	8000
	M 42	15000	10000	30000	20000	14000	10000	21200	15000	10000	10000
RGS	M 8	400	---	800	---	---	---	---	---	---	---
	M 10	700	---	1400	---	---	---	---	---	---	---
	M 12	1000	---	2000	---	---	---	---	---	---	---
	M 14	1200	---	2400	---	---	---	---	---	---	---
	M 16	1500	---	3000	---	---	---	---	---	---	---
	M 20	2500	---	5000	---	---	---	---	---	---	---
DIN 580	M 6	70	---	140	---	50	---	---	---	---	---
	M 8	140	---	280	---	95	---	---	---	---	---
	M 10	230	---	460	---	170	---	---	---	---	---
	M 12	340	---	680	---	240	---	---	---	---	---
	M 14	490	---	960	---	350	---	---	---	---	---
	M 16	700	---	1400	---	500	---	---	---	---	---
	M 18	900	---	1800	---	640	---	---	---	---	---
	M 20	1200	---	2400	---	830	---	---	---	---	---
	M 22	1500	---	3000	---	1000	---	---	---	---	---
	M 24	1800	---	3600	---	1270	---	---	---	---	---
	M 27	2500	---	5000	---	1800	---	---	---	---	---
	M 30	3600	---	7200	---	2600	---	---	---	---	---
	M 33	4300	---	8600	---	3000	---	---	---	---	---
	M 36	5100	---	10200	---	3700	---	---	---	---	---
	M 39	6100	---	12200	---	4300	---	---	---	---	---
	M 42	7000	---	14000	---	5000	---	---	---	---	---
	M 45	8000	---	16000	---	5700	---	---	---	---	---
	M 48	8600	---	17200	---	6100	---	---	---	---	---
	M 56	11500	---	23000	---	8300	---	---	---	---	---
	M 64	16000	---	32000	---	11000	---	---	---	---	---
M 72	21000	---	42000	---	29400	---	---	---	---	---	
M 80	28000	---	56000	---	39200	---	---	---	---	---	
M 100	38000	---	76000	---	53200	---	---	---	---	---	
GLU	M 12	500	---	1000	---	700	---	1000	---	---	---
	M 14	800	---	1600	---	1100	---	1600	---	---	---
	M 16	1200	---	2400	---	1600	---	2500	---	---	---
	M 20	1600	---	3200	---	2200	---	3300	---	---	---
	M 22	2000	---	4000	---	2800	---	4200	---	---	---
	M 24	2500	---	5000	---	3500	---	5200	---	---	---
	M 30	4000	---	8000	---	5600	---	8400	---	---	---
	M 36	6300	---	12600	---	8800	---	13200	---	---	---

OGNIWO DO PRZYSPAWANIA CAW

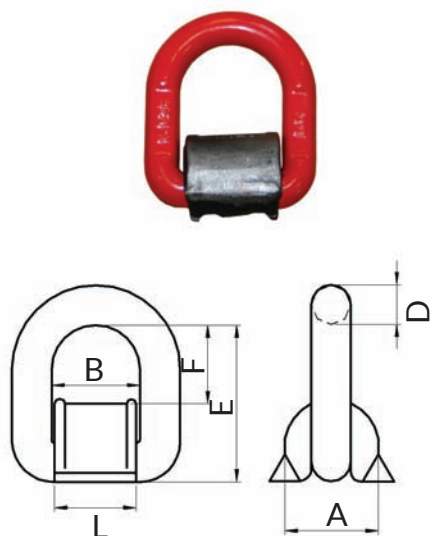

Typ	DOR [kg]	MBL [kN]	E [mm]	D [mm]	F [mm]	B [mm]	A [mm]	L [mm]	Masa [kg/szt.]	Spoina a min [mm]
CAW 6	1120	43,9	63	13,5	37	40	38	37	0,40	10
CAW 8	2000	78,5	73	14,5	42	42	40	40	0,45	12
CAW 10	3150	124,0	75	17,5	42	45	43	44	0,75	14
CAW 13	5300	208,0	94	22,5	56	55	60	49	1,45	18
CAW 16	8000	314,0	112	27	62	69	70	66	2,35	22
CAW 22	15000	588,0	154	34	86	96	88	88	5,35	30

OGNIWO Z KOŃCÓWKĄ GWINTOWANĄ CAT

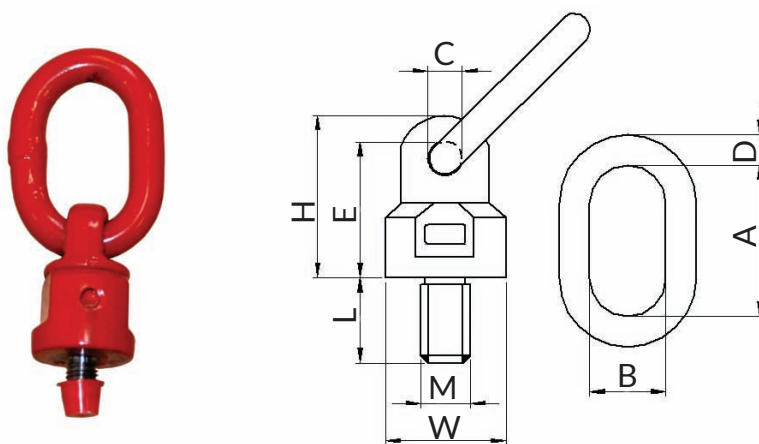

Rozmiar M [mm]	DOR [t]		MBL [kN]	A [mm]	B [mm]	C [mm]	D [mm]	E [mm]	L [mm]	H [mm]	W [mm]	Masa [kg/szt.]
	0°	90°										
M 8	0,6	0,3	23,5	50	31	16	13	44	13	53	36,5	0,40
M 10	1	0,5	35,3	50	31	16	13	44	18	53	36,5	0,43
M 12	1	0,5	39,2	50	31	16	13	44	18	53	36,5	0,44
M 16	2	1,12	78,5	50	31	16	13	44	20	53	36,5	0,46
M 20	4	2	157,0	72	32	19	16	56	30	69	50	1,00
M 24	6,3	3,15	247,1	85	38	22	18	66	30	79	57	1,45
M 30	10,6	5,3	415,8	84	38	23,5	20	82	35	98	66,5	2,20
M 30 D	11,8	8	462,9	114	53	30	21	95	35	110	80	3,55
M 36	11,8	8	462,9	113	49	27	22	86	50	108	80	3,75
M 42	15	10	588,4	115	49	28	25,5	92	50	108	80	4,15

UCHO LINOWE Z GWINTEM GLU

Rozmiar M [mm]	DOR [t]	MBL [kN]	H [mm]	E [mm]	D [mm]	W [mm]	Masa [kg]
M 10	0,33	16,2	114	20	5,5	38	0,05
M 12	0,5	24,5	128	22	6,0	40	0,06
M 14	0,8	39,2	155	25	6,5	55	0,08
M 16	1,2	58,8	175	28	9	58	0,1
M 20	1,6	78,5	210	35	10	65	0,2
M 24	2,5	122,6	255	45	12	80	0,4
M 30	4,0	196,1	300	58	16	87	0,9

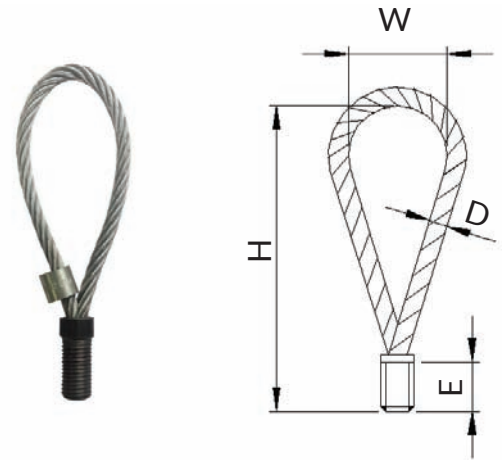

ŚRUBA Z UCHEM DIN 580

Ø D [mm]	DOR [t]	A [mm]	F [mm]	L [mm]	E [mm]	M [mm]	Masa [kg/szt.]
M 6*	0,07	8	20	49	20	13	0,06
M 8	0,14	8	20	49	20	13	0,06
M 10	0,23	10	25	62	25	17	0,11
M 12	0,34	12	30	73,5	30	20,5	0,18
M 14*	0,49	14	35	89	35	27	0,35
M 16	0,7	14	35	89	35	27	0,35
M 18*	0,9	16	40	101	40	30	0,45
M 20	1,2	16	40	101	40	30	0,45
M 22*	1,5	20	50	126	50	36	0,74
M 24	1,8	20	50	126	50	36	0,74
M 27	2,2	24	60	154	65	45	1,66
M 30	3,2	24	60	154	65	45	1,66
M 33*	3,8	24	60	154	65	45	2,65
M 36	4,6	28	70	182	75	54	2,65
M 39*	5,4	32	80	210	85	63	4,0
M 42	6,3	32	80	210	85	63	4,0
M 45*	8,0	38	90	236	100	68	6,4
M 48	8,6	38	90	236	100	68	6,4
M 56	11,5	42	100	265	110	78	8,8
M 64	16,0	48	110	298	120	90	12,4
M 72	21	59	130	336	148	105	22,5
M 20 x 2	1,2	16	40	101	40	30	0,45
M 24 x 2	1,8	20	50	126	50	36	0,74
M 30 x 2	3,2	24	60	154	65	45	1,66
M 33 x 2	3,8	24	60	154	65	45	2,65
M 36 x 3	4,6	28	70	182	75	54	2,65
M 42 x 3	6,3	32	80	210	85	63	4,0
M 48 x 3	8,6	38	90	236	100	68	6,4

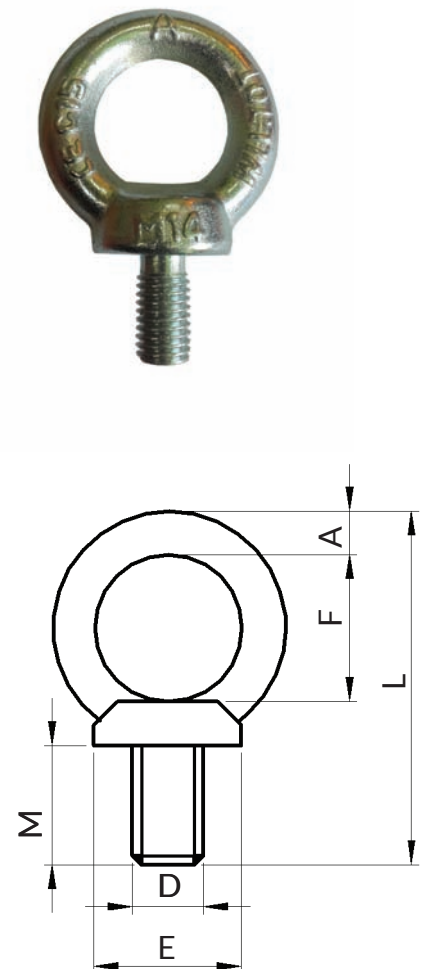

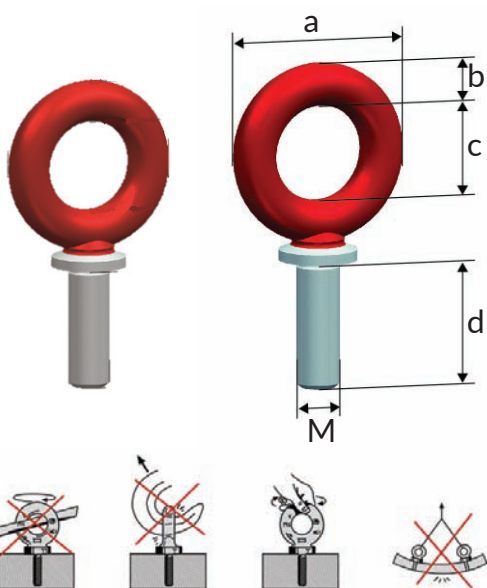

ŚRUBA Z UCHEM RGS



Typ	DOR [kg]	Gwint	c [mm]	a [mm]	d [mm]	b [mm]	Masa [kg/szt.]
RGS 8	400	M 8	20,0	36	25	8	0,06
RGS 10	700	M 10	22,0	42	30	10	0,10
RGS 12	1.000	M 12	26,7	51	36	12	0,20
RGS 14	1.200	M 14	30,0	58	40	14	0,30
RGS 16	1.500	M 16	36,0	66	53	16	0,40
RGS 20	2.500	M 20	40,0	76	58	18	0,70
RGS 24	4.000	M 24	54,0	98	82	22	1,32

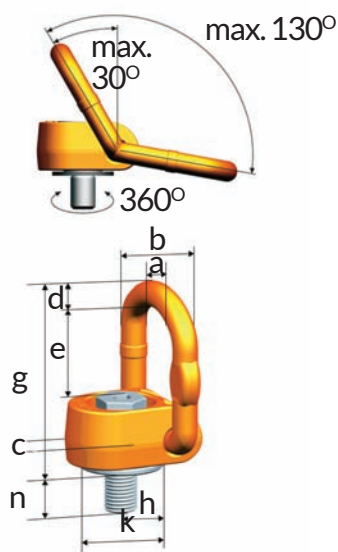

PUNKT MOCUJĄCY PLAW

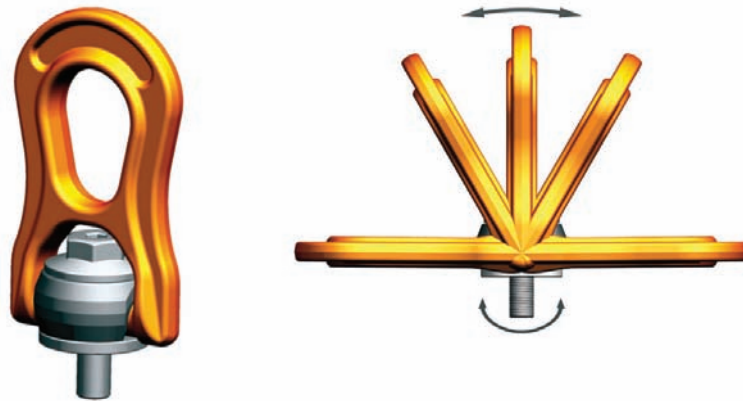
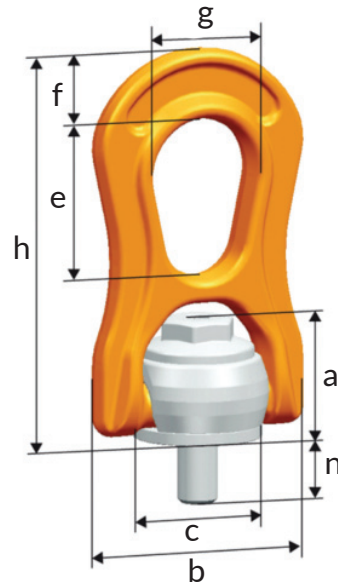

Typ	Gwint	DOR [kg]	a [mm]	b [mm]	c [mm]	d [mm]	e [mm]	g [mm]	h [mm]	k [mm]	n [mm]	n max. [mm]	 [mm]	 [mm]	Masa [kg/szt.]
PLAW 0,3t	M8	300	45	67	40	11	41	95	36	55	20	150	10	24	0,57
PLAW 0,63t	M10	630	45	67	40	11	41	95	36	55	20	150	10	24	0,58
PLAW 1t	M12	1000	45	67	40	11	41	95	36	55	33	170	10	24	0,6
PLAW 1,5t	M16	1500	45	67	40	11	41	95	36	55	33	260	10	24	0,62
PLAW 2,5t	M20	2500	54	81	50	13	55	112	50	67	33	335	8	24	1,10
PLAW 4t	M24	4000	54	87	50	17	67	142	45	70	36	361	14	36	1,6
PLAW 6t	M30	6000	75	115	67	20	68	143	67	100	49	364	14	36	3,10
PLAW 7t *	M36	7000	75	115	67	20	65	143	60	100	55	374	27	-	3,30
PLAW 8t	M36	8000	93	147	85	27	87	188	85	120	55	365	19	36	6,10
PLAW 10t	M42	10000	93	147	85	27	87	188	85	120	65	290	32	-	6,40
PLAW 15t	M42	15000	115	181	105	33	108	246	106	150	63	340	19	55	12,00
PLAW 20t	M48	20000	115	181	105	33	108	246	106	150	73	340	19	55	12,30

PUNKT MOCUJĄCY PLBW



Typ	Gwint	DOR [kg]	a [mm]	b [mm]	c [mm]	e [mm]	f [mm]	g [mm]	h [mm]	n [mm]	n max. [mm]	 [mm]	 [mm]	Masa [kg/szt.]
PLBW 0,3 t	M8	300	29	56	30	38	18	27	94	13	80	8	15	0,32
PLBW 0,6 t	M10	600	29	56	30	38	18	27	94	15	100	8	15	0,33
PLBW 1 t	M12	1.000	29	56	30	38	18	27	94	17	180	8	15	0,34
PLBW 1,3 t	M14	1.300	43	79	45	55	25	38	138	22	220	10	24	1,03
PLBW 1,6 t	M16	1.600	43	79	45	55	25	38	138	24	260	10	24	1,04
PLBW 2 t	M18	2.000	43	79	45	55	25	38	138	27	295	10	24	1,07
PLBW 2,5 t	M20	2.500	43	79	45	55	25	38	138	30	355	10	24	1,08
PLBW 3 t	M22	3.000	64	118	68	85	38	58	209	33	355	14	36	3,50
PLBW 4 t	M24	4.000	64	118	68	85	38	58	209	36	355	14	36	3,53
PLBW 5 t	M27	5.000	64	118	68	85	38	58	209	40	355	14	36	3,58
PLBW 6,3 t	M30	6.300	64	118	68	85	38	58	209	45	355	14	36	3,66
PLBW 8 t	M33	8.000	106	188	108	132	60	91	331	54	328	19	55	14,5
PLBW 10 t	M36	10.000	106	188	108	132	60	91	331	59	328	19	55	14,6
PLBW 12,5 t	M42	12.500	106	188	108	132	60	91	331	69	328	19	55	14,90
PLBW 15 t	M48	15.000	106	188	108	132	60	91	331	74	328	19	55	15,20

PUNKT MOCUJĄCY PLGW

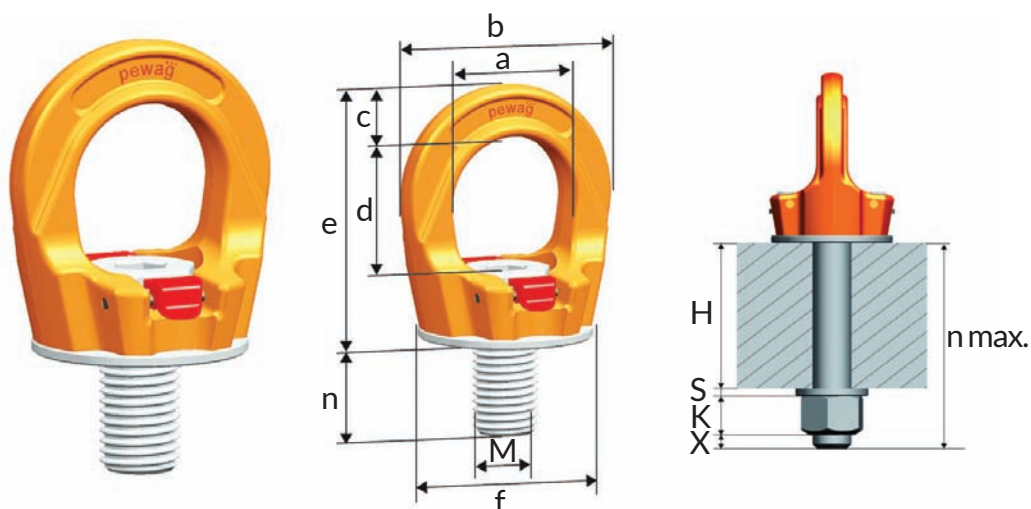

Typ	Gwint	DOR [kg]	a [mm]	b [mm]	c [mm]	d [mm]	e [mm]	Øf [mm]	n [mm]	n max. [mm]	 [mm]	Masa [kg/szt.]
PLGW 0,3	M8	300	25	45	10	27	53	35	15	90	6	0,17
PLGW 0,5	M10	500	25	45	10	27	53	35	15	160	6	0,18
PLGW 0,7	M12	700	30	55	12	32	63	43	20	160	8	0,29
PLGW 1,5	M16	1.500	35	64	14	36	70	50	25	160	10	0,45
PLGW 2,3	M20	2.300	40	73	16	41	81	54	30	160	12	0,58
PLGW 3,2	M24	3.200	50	86	18	50	93	69	35	-	14	1,10
PLGW 4	M30	4.000	60	110	25	60	114	90	45	-	17	2,20
PLGW 7	M36	7.000	70	132	31	70	136	108	55	-	19	3,90
PLGW 9	M42	9.000	80	152	36	72	153	126	65	-	22	5,80
PLGW 12	M48	12.000	95	179	42	88	179	148	75	-	24	8,9

PUNKT MOCUJĄCY AOR

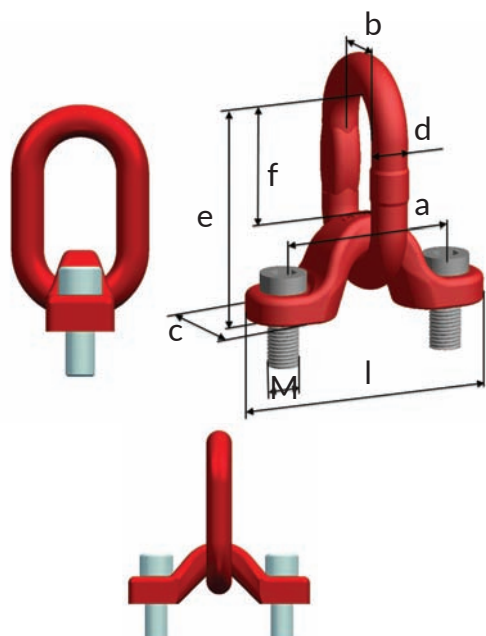

Typ	DOR [kg]	Gwint	Ø mm	A [mm]	B [mm]	C [mm]	D [mm]	E [mm]	F [mm]	L [mm]	Masa [kg/szt.]
AOR 10	3150	M 16	10	90	40	38	18	112	57	130	1,54
AOR 13	5300	M20	13	115	50	48	22	149	79	165	2,83
AOR 16	8000	M 30	16	150	65	62	26	183	93	212	5,87
AOR 22	15000	M 36	22	175	75	72	36	226	114	255	11,2
AOR 26 *	21200	M 42	26	200	95	90	45	272	142	295	19,3
AOR 28 *	25000	M 45	28	200	95	90	45	272	142	295	20,2
AOR 32 *	31500	M56	32	230	110	100	48	336	193	330	31,7
AOR 34 *	36000	M56	34	230	110	100	48	336	193	330	31,7

UCHWYTY, CHWYTAKI

UCHWYT DO PODNOSZENIA BLACH W POZYCJI PIONOWEJ Z PRZEGUBEM CNP

Typ	DOR [t]	Zakres chwytania A [mm]	H [mm]	W [mm]	B [mm]	G [mm]	F [mm]	Masa [kg/szt.]
CNP 0,5	0,5	0 - 15	215	110	48	30	10	1,9
CNP 1,0	1,0	0 - 20	300	150	65	48	13	4,6
CNP 2,0	2,0	0 - 25	360	180	70	68	17	7,1
CNP 3,0	3,0	0 - 30	435	205	100	75	21	15,3
CNP 5,0	5,0	0 - 52	470	235	100	75	21	17,7
CNP 8,0	8,0	40 - 80	600	290	115	84	25	50,0
CNP 12,0	12,0	50 - 90	730	450	120	80	25	65,0

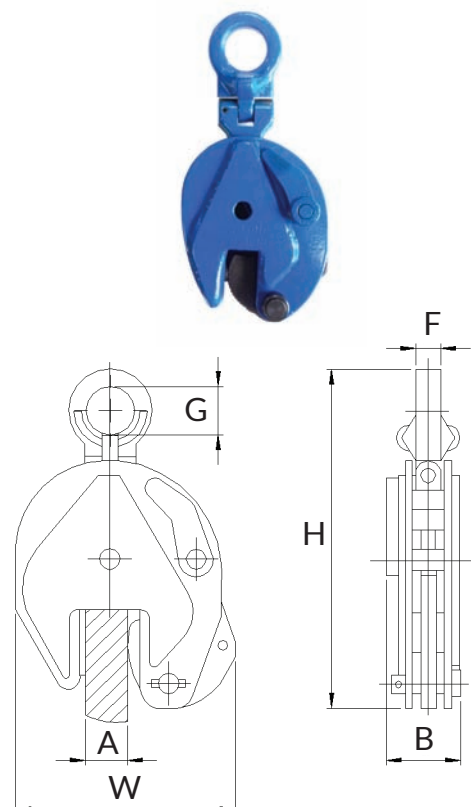

UCHWYT DO PODNOSZENIA BLACH W POZYCJI POZIOMEJ CNH

Typ	DOR [t]	DOR dla pary [t]	Zakres chwytania A [mm]	H max [mm]	W [mm]	B [mm]	G [mm]	F [mm]	Masa [kg/szt.]
CNH 0,75	0,75	1,5	0 - 50	218	127	100	30	15	4,0
CNH 1,5	1,5	3,0	0 - 50	270	220	110	36	20	7,5
CNH 2,5	2,5	5,0	0 - 60	315	260	130	40	22	14
CNH 4,0	4,0	8,0	0 - 100	400	300	170	40	25	29

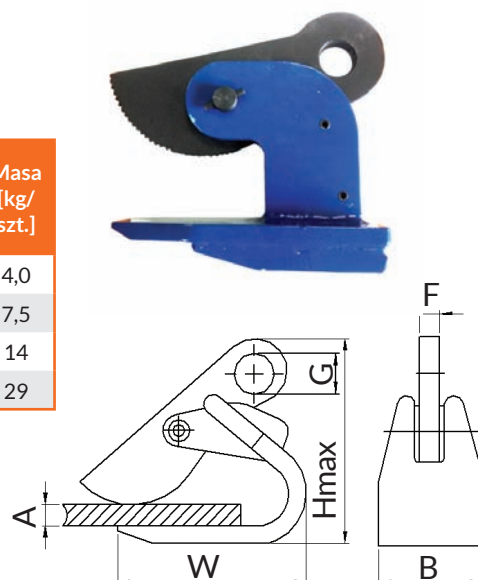

UCHWYT DO PODNOSZENIA BLACH W POZYCJI POZIOMEJ CNI

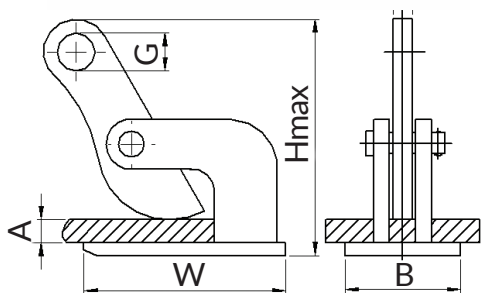

Typ	DOR [t]	Zakres chwytania A [mm]	H max [mm]	W [mm]	B [mm]	G [mm]	F [mm]	Masa [kg/szt.]
CNI 0,75	0,75	0 - 25	152	162	79	22	14	4,1
CNI 1,5	1,5	0 - 35	186	193	99	22	15	7,6
CNI 3,0	3,0	0 - 40	215	196	104	30	17	9,7

UCHWYT DO PODNOSZENIA PAKIETÓW BLACH W POZYCJI POZIOMEJ HSKW

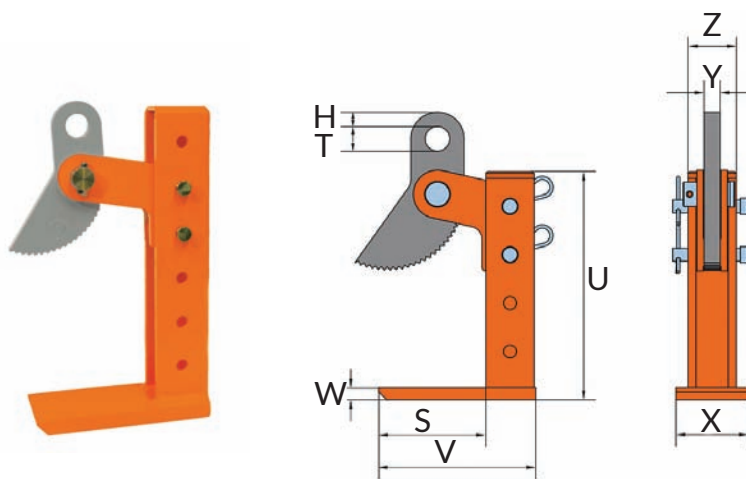

Typ	DOR NA PARĘ [kg]	R [mm]	V [mm]	S [mm]	W [mm]	T [mm]	H [mm]	U [mm]	X [mm]	Z [mm]	Y [mm]	Masa [kg/szt.]
HSKW/180 1.5 t	1500	3-180	201	135	15	30,5	18	289	90	60	20	9,50
HSKW/300 1.5 t	1500	3-300	201	135	15	30,5	18	409	90	60	20	11,00
HSKW/180 3 t	3000	3-180	241	165	20	30,5	18	296	105	69	20	13,00
HSKW/300 3 t	3000	3-300	241	165	20	30,5	18	416	105	69	20	15,00
HSKW/180 4.5 t	4500	3-180	241	165	20	30,5	18	296	105	69	20	13,00
HSKW/420 4.5 t	4500	3-420	241	165	20	30,5	18	536	105	69	20	17,00
HSKW/180 6 t	6000	3-180	256	160	25	30,5	18	304	120	75	20	18,00
HSKW/420 6 t	6000	3-420	256	160	25	30,5	18	544	120	75	20	24,00
HSKW/180 9 t	9000	3-180	256	160	25	30,5	18	304	120	75	20	18,00
HSKW/420 9 t	9000	3-420	256	160	25	30,5	18	544	120	75	20	24,00

UCHWYT DO PODNOSZENIA
BLACH NIERDZEWNYCH W POZYCJI PIONOWEJ VNMW

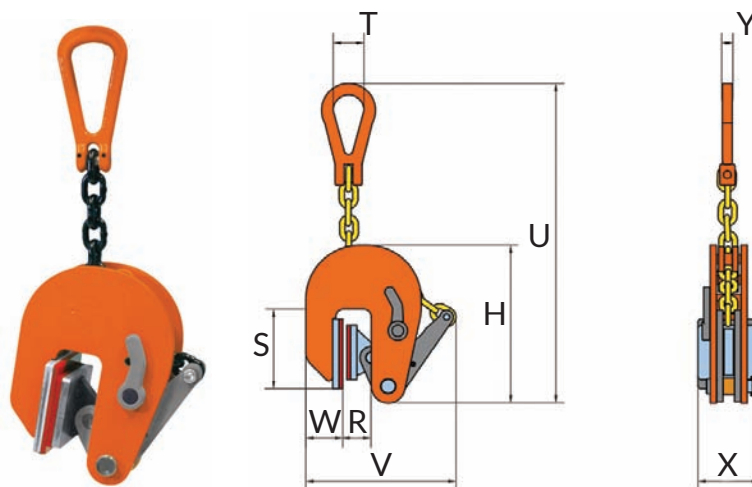

Typ	DOR [kg]	R [mm]	H [mm]	S [mm]	T [mm]	U [mm]	V [mm]	W [mm]	X [mm]	Y [mm]	Masa [kg/szt.]
VNMW 0.5 t	500	1-20	205	102	40	462	224	48	80	14	6,00
VSNMW 0.5 t	500	17-37	205	102	40	462	241	48	80	14	6,00
VNMW 1 t	1000	1-30	232	105	40	470	282	46	80	14	6,50
VNMW 1.5 t	1500	1-40	232	105	40	470	282	46	80	14	6,50
VNMW 2 t	2000	1-50	362	124	50	704	408	63	80	18	15,00
VNMW 3 t	3000	1-60	362	124	50	704	408	63	80	18	15,50

UCHWYT DO PODNOSZENIA BLACH NIERDZEWNYCH
I INNYCH DELIKATNYCH PŁYT W POZYCJI POZIOMEJ NMHW

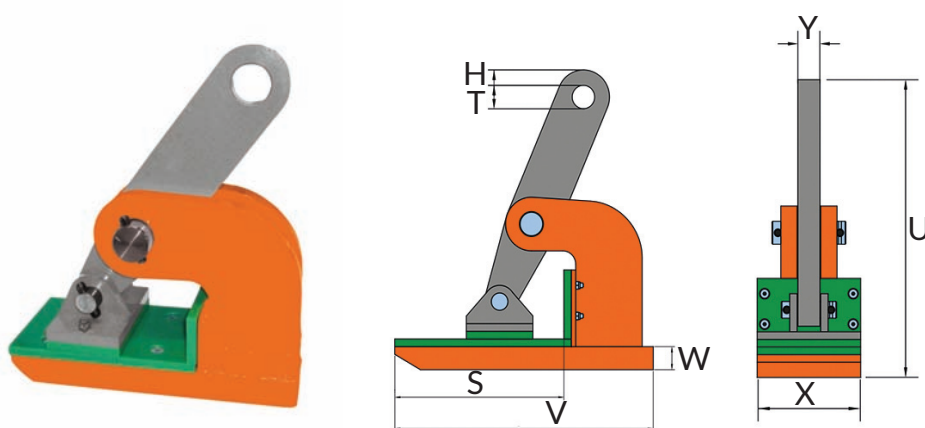

Typ	DOR NA PARĘ [kg]	R [mm]	V [mm]	S [mm]	W [mm]	T [mm]	H [mm]	U [mm]	X [mm]	Y [mm]	Masa [kg/szt.]
NMHW 1 t	1000	0-25	140	94	15	20	10	155	65	15	2,40
NMHW 2 t	2000	0-45	225	151	23	30,5	15	267	90	15	7,50
NMHW 3 t	3000	0-45	225	151	20	30,5	15	271	90	15	8,30
NMHW 4 t	4000	0-50	250	161	20	30,5	17,5	300	115	30	13,00
NMHW 6 t	6000	0-50	250	161	25	30,5	17,5	306	130	30	18,00

UCHWYT ŚRUBOWY CUS

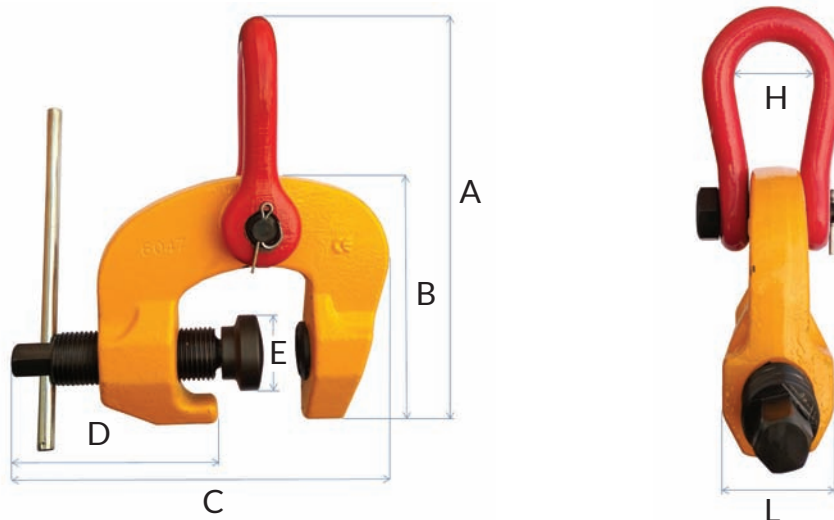

Typ	DOR [t]	Zakres [mm]	C [mm]	A [mm]	D [mm]	E [mm]	B [mm]	L [mm]	H [mm]	Masa [kg]
CUS 0,5	0,5	0-28	127	116	89	26	75	30	17	0,8
CUS 0,75	0,75	0-22	167	201	120	42	125	46	38	3,0
CUS 1500	1,5	0-32	187	226	135	42	142	46	45	4,0
CUS 3000	3,0	0-50	223	268	165	49	165	55	50	7,0
CUS 6000	6,0	0-75	285	364	215	63	210	70	80	18

ZAWIESIE KLAMROWE CZKS

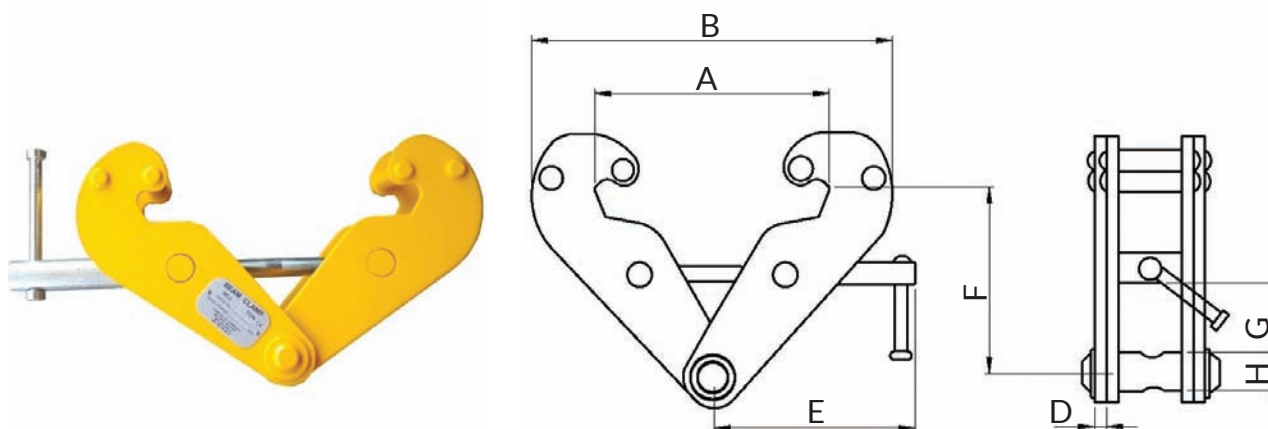

Typ	DOR [kg]	A [mm]	B [mm]	C [mm]	D [mm]	E [mm]	F [mm]	G [mm]	Masa [kg/szt.]
UK - 1	1000	334	85-240	186	90	23	20	120	3,9
UK - 2	2000	334	85-240	220	106	23	20	120	4,5
UK - 3	3000	460	80-320	232	131	30	30	174	10,0
UK - 5	5000	465	90-320	240	126	34	35	182	12,8

UCHWYT DO RUR POR

Typ	DOR /para uchwytów [kg]	A [mm]	B [mm]	H [mm]
POR 1,5	1 500	70	34	125
POR 3,0	3 000	70	34	125
POR 4,0	4 000	70	40	125

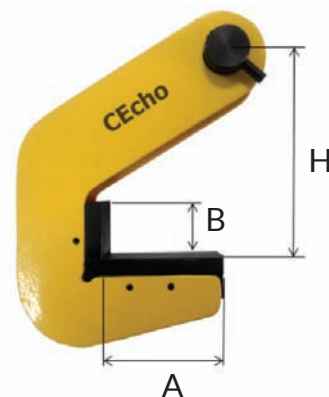

UCHWYT WIDŁOWY DO PALET Z MANUALNYM WYWAŻANIEM MUW

Typ	DOR [kg]	A [mm]	B [mm]	C [mm]	D [mm]	E [mm]	F [mm]	Masa [kg/szt.]
MUW 1,0	1000	1250-1750	980	250-880	720	255	100	140
MUW 1,5	1500	1250-1750	1080	250-880	720	255	100	172
MUW 2,0	2000	1250-1750	1180	250-880	720	290	120	198
MUW 3,0	3000	1300-2050	1000	450-880	720	315	120	240

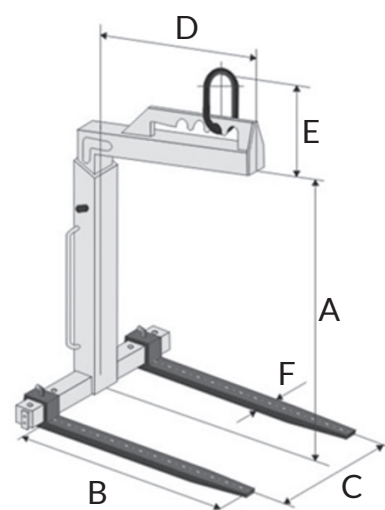

UCHWYT WIDŁOWY DO PALET Z AUTOMATYCZNYM WYWAŻANIEM AUW

Typ	DOR [kg]	A [mm]	B [mm]	C [mm]	D [mm]	E [mm]	F [mm]	G [mm]	Masa [kg/szt.]
AUW 1,0	1000	350 - 900	1100 - 1600	1000	100	30	100	27	140
AUW 1,5	1500	350 - 900	1300 - 2000	1000	100	40	100	27	165
AUW 2,0	2000	400 - 900	1300 - 2000	1000	120	40	115	32	220
AUW 3,0	3000	450 - 900	1300 - 2000	1000	120	50	-	-	-
AUW 5,0	5000	500 - 1000	1300 - 2000	1000	150	60	-	-	-

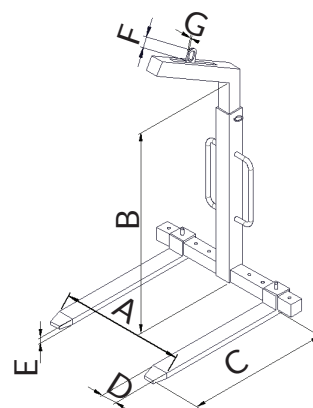



ZAWIESIE DO KRĘGÓW BETONOWYCH CKB

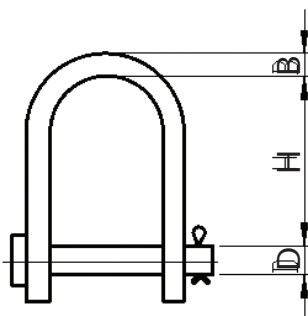
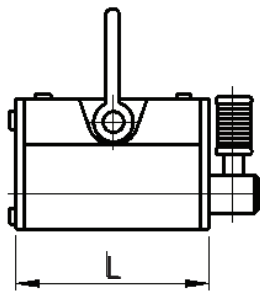
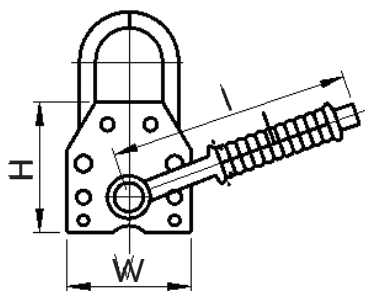

Typ	DOR [t]	Dla średnicy kręgów [mm]	Zakres chwytania [mm]	Długość zawiesia [mm]	Masa [kg]
CKB 1,5	1,5	400-2000	40-120	2000	34
CKB 3,0S	3,0	400-2000	50-160	2000	55
CKB 3,0	3,0	400-2000	50-180	2000	71
CKB 3,0L	3,0	400-2000	90-220	2000	76
CKB 4,0	4,0	400-3000	90-220	2500	90

UCHWYT MAGNETYCZNY PML



TYP	DOR[t]		Wymiary[mm]				Masa[kg]
			H	W	L	I	
PML 0,1	0,1	0,03	67	62	92	126	3,0
PML 0,3	0,3	0,1	91	92	162	155	10,0
PML 0,6	0,6	0,2	117	122	232	196	24,0
PML 1,0	1,0	0,3	163	176	258	285	50,0
PML 2,0	2,0	0,6	212	234	378	426	125,0
PML 3,0	3,0	1,0	261	286	458	521	220,0
PML 6,0	6,0	2,0	266	296	720	700	398,0

UCHWYT MAGNETYCZNY NEO

- UWAGA - W OFERCIE RÓWNIEŻ WERSJA DO PODNOSZENIA ELEMENTÓW GORĄCYCH - NEO HOT

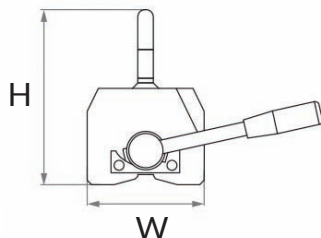
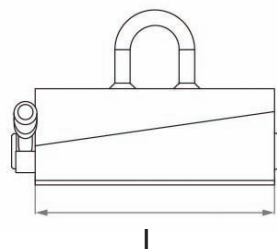

Numer katalogowy	W [mm]	L [mm]	H [mm]	Średnica ucha [mm]	Masa [kg]	Maks. testowany udźwig [kg]	Udźwig dla materiału płaskiego [kg]	Udźwig dla materiału okrągłego [kg]	Min/maks średnia [mm]
NEOL150	60	93	120	10	3	450	150	65	40/100
NEOL300	100	152	180	16	10	900	300	150	60/200
NEOL600	120	246	180	20	21	1800	600	300	65/270
NEOL1000	146	306	236	20	40	3200	1000	500	100/300
NEOL1500	165	374	273	20	69	4700	1500	750	150/350
NEOL2000	165	478	273	20	90	6200	2000	1000	150/350

UCHWYT MAGNETYCZNY DO RĘCZNEGO PODNOSZENIA I MANIPULACJI MC

Numer katalogowy	W [mm]	L [mm]	H [mm]	Maks. udźwig [kg]	Masa [kg]
MC-2	150	160	27	60	1,4
MC-2S	160	230	24	90	2,9



UCHWYT MAGNETYCZNY BATERIOWY ZE ZDALNYM STEROWANIEM BM

Numer katalogowy	Udźwig dla materiału płaskiego (kg)	Testowany udźwig (kg)	W x L podstawy (mm)	Wyso-kość z uchem włącznie (mm)	Masa (mm)	Wbudowa-na bateria	Typ baterii
BM1350	1350	2700	242 x 272	460	60	12V/35Ah	FG12 - 35D
BM2500	2500	5000	242 x 400	460	72	12V/75Ah	FG12 - 75D
BM3600	3600	7200	240 x 1050	460	180	12V/75Ah	FG12-75D
BM5000	5000	10000	300 x 1200	460	203	12V/75Ah	FG12-75D

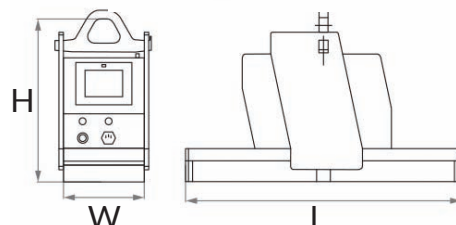

WCIĄGNIKI, WÓZKI, PODNOŚNIKI

- Spełniają wymagania dyrektywy maszynowej 2006/42/WE
- Narzędzia charakteryzują się lekką i ergonomiczną konstrukcją
- Znakowanie: udźwig, znak CE, nazwa producenta/dystrybutora, numer seryjny,
- Dokumenty: deklaracja zgodności, świadectwo jakości 2.1, instrukcja użytkownika

WCIĄGNIK ŁAŃCUCHOWY DŹWIGNIOWY CKS

- Standardowo 1,5m długości łańcucha (możliwość wykonania na dowolną wysokość podnoszenia)
- Ergonomiczny uchwyt dźwigni
- Obrotowy hak w korpusie i na końcu łańcucha

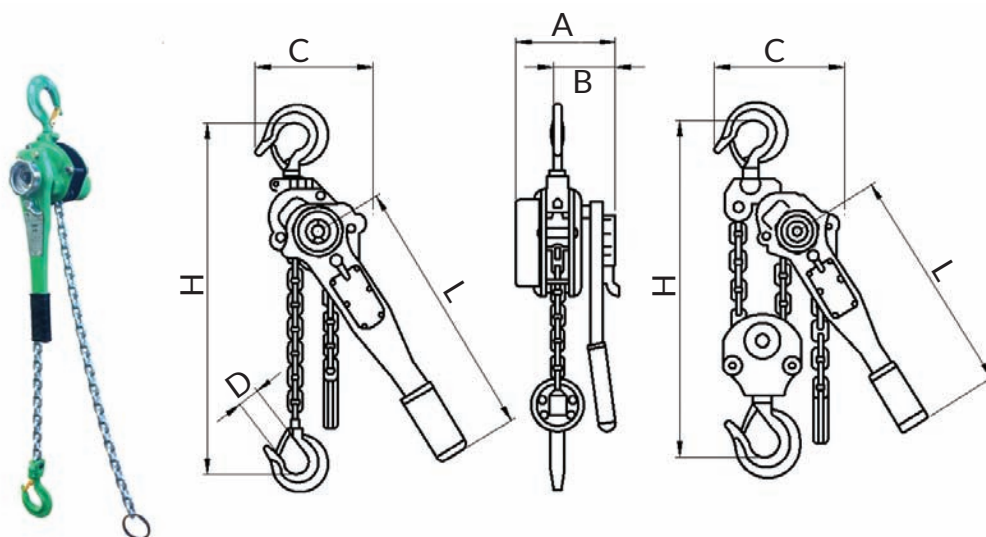

Typ	DOR [t]	Wysokość podnoszenia [m]	Ilość cięgieł łańcucha	Średnica łańcucha [mm]	Minimalna wysokość H [mm]	A [mm]	B [mm]	C [mm]	D [mm]	L [mm]	Masa [kg]
CKS 0,25	0,25	1	1	4	245	92	71	70	18	158	2,3
CKS 0,50	0,50	1,5	1	5	300	143	86	118	20	253	3,5
CKS 0,75	0,75	1,5	1	6	325	148	90	136	22	280	6,5
CKS 1,5	1,5	1,5	1	8	380	172	98	160	31	410	11
CKS 3,0	3	1,5	1	10	480	200	115	180	32	410	18,1
CKS 6,0	6	1,5	2	10	620	200	115	235	37	410	27,7
CKS 9,0	9	1,5	3	10	700	203	115	316	53	410	47

WCIĄGNIK ŁAŃCUCHOWY RĘCZNY WLC

- Lekka i wygodna konstrukcja
- Standardowo 3,0 m długości łańcucha (możliwość wykonania na dowolną wysokość podnoszenia)
- Obrotowy hak w korpusie i na końcu łańcucha

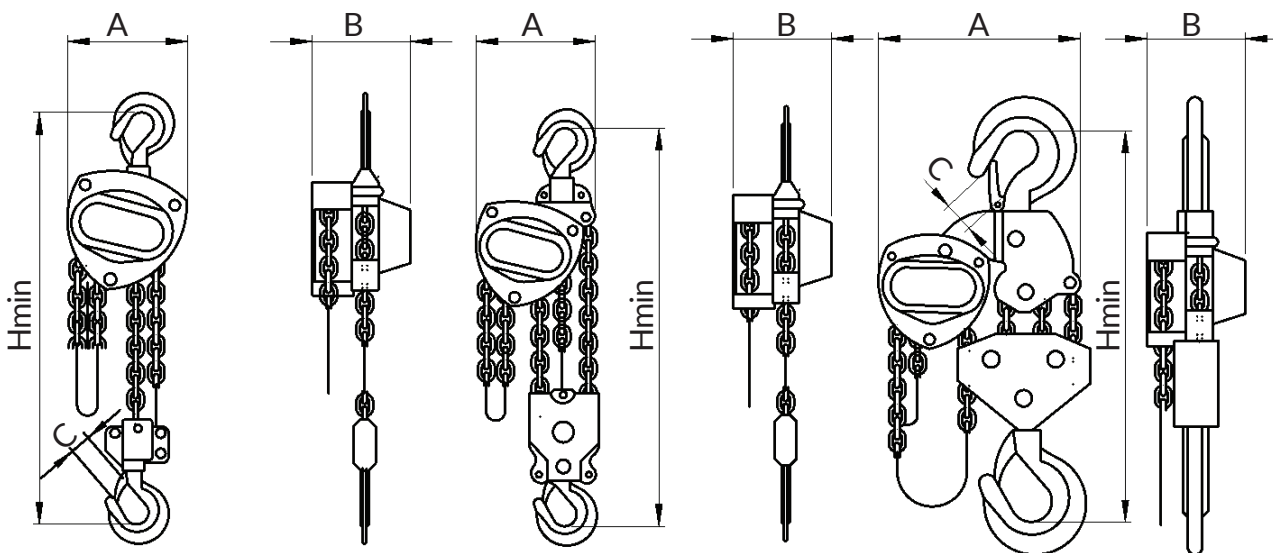

Typ	DOR [t]	Wysokość podnoszenia [m]	Wysokość manewrowania [m]	Ilość cięgien łańcucha	Siła podnoszenia [N]	Średnica łańcucha [mm]	Minimalna wysokość H [mm]	A [mm]	B [mm]	C [mm]	Masa [kg]
WLC 0,5	0,5	3	3	1	231	6	270	131	127	21	9,1
WLC 1,0	1	3	3	1	309	6	317	140	158	23	11,3
WLC 2,0	2	3	3	1	360	8	414	161	187	27	17,8
WLC 3,0	3	3	3	2	340	8	465	161	199	36	24,1
WLC 5,0	5	3	3	2	414	10	636	186	253	42	41,1
WLC 10,0	10	3	3	4	414	10	798	207	398	64	9,5

WÓZEK JEZDNY Z NAPĘDEM WZN

- Przeznaczony do podwieszania wciągników na profilu nośnym
- Możliwość ustawienia szerokości wózka do określonej szerokości kształtownika
- Przejazd wózkiem następuje poprzez ciągnięcie łańcucha

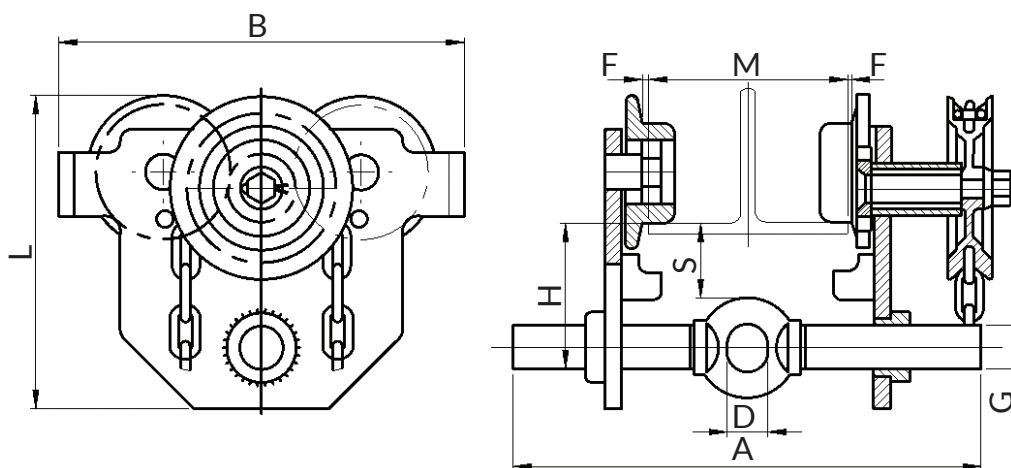

TYP:		WZN 1	WZN -W 1	WZN 2	WZN -W 2	WZN 3	WZN -W 3	WZN 5	WZN -W 5
Udźwig [kg]:		1 000	1 000	2 000	2 000	3 000	3 000	5 000	5 000
Wysokość manewrowa łańcucha [m]:		2,5 - istniejąca możliwość przerobienia na dowolny wymiar							
Zalecana szerokość profilu [mm]:	M	50-220	160-305	66-220	160-305	74-220	160-305	90-220	160-305
Wymiary [mm]:	A	300	388	314	400	328	415	346	432
	B	245	245	276	376	335	335	377	377
	C	190	190	222	222	262	262	292	292
	D	30	30	40	40	46	46	52	52
	G	30	30	48	48	58	58	65	65
	H	95	95	106	106	121	121	136	136
	S	43	43	38	38	40	40	42	42
Masa [kg]:		13,0	16,5	18,5	29,0	37,5	42,5	40,0	48,0

WÓZEK JEZDNY BEZ NAPĘDU WBN

- Przeznaczony do podwieszania wciągników na profilu nośnym
- Możliwość ustawienia szerokości wózka do określonej szerokości kształtownika

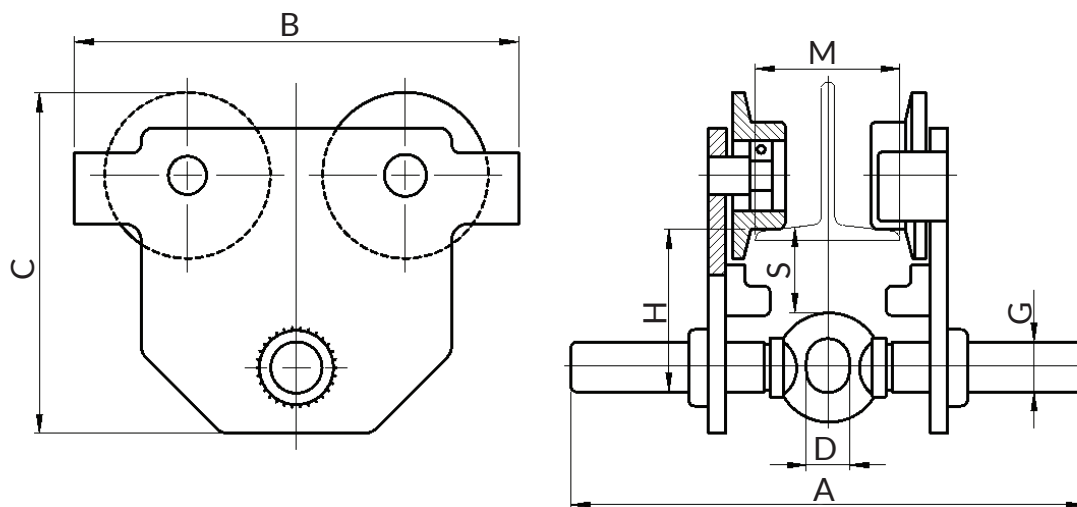
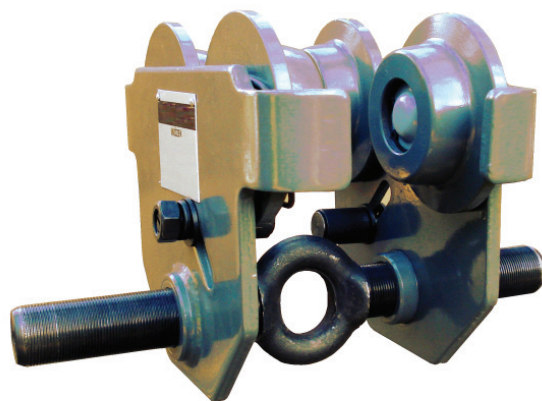

TYP:	WBN 0,5	WBN 1	WBN-W 1	WBN 2	WBN -W 2	WBN 3	WBN -W 3	WBN 5	WBN -W 5	
Udźwig [kg]:	500	1 000	1 000	2 000	2 000	3 000	3 000	5 000	5 000	
Zalecana szerokość profilu [mm]:	M	50-220	50-220	160-305	66-220	160-305	74-220	160-305	90-220	160-305
Wymiary [mm]:	A	288	300	388	305	400	314	400	346	432
	B	205	245	252	284	276	335	335	377	377
	C	162	188	188	202	222	262	262	262	262
	D	25	30	30	35	40	46	46	46	46
	G	30	36	36	40	48	58	58	58	58
	H	74	90	90	95	106	121	121	121	121
	S	32	36	36	38	38	40	40	40	40
Masa produktu [kg]:	5,0	9,0	12,5	14,5	15,5	23,5	38,5	36,0	39,6	

PODNOŚNIK MECHANICZNY - KORBOWY PKC

- Stosowany do podnoszenia i przesuwania maszyn i pojazdów

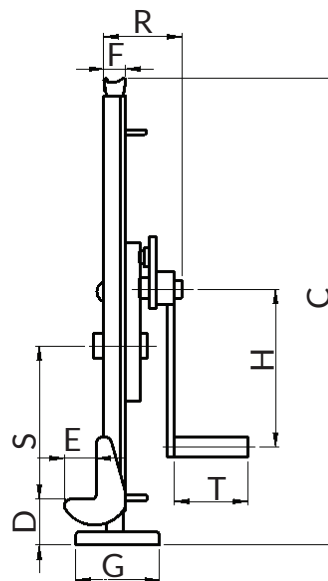
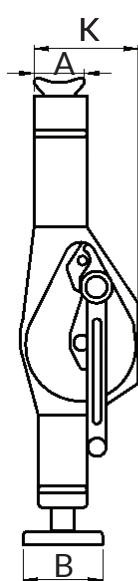

TYP:	PKC 1,5	PKC 3,0	PKC 5,0	PKC 10	PKC 16	
Udźwig [kg]:	1 500	3 000	5 000	10 000	16 000	
Udźwig na łapie [kg]:	1 000	2 100	3 500	7 000	11 000	
Siła na korbie [N]:	190	196	235	431	580	
Wymiary [mm]:	A	78	85	105	120	133
	B	103	130	143	146	150
	C	600 - 905	720 - 1080	730 - 1080	790 - 1130	800 - 1135
	D	50 - 355	60 - 420	70 - 420	80 - 420	90 - 425
	E	55	60	67	72	75
	F	38	47	65	75	83
	G	112	140	175	178	182
	H	230	290	290	300	300
	K	125	170	190	250	270
	R	115	130	145	170	185
S	185	235	225	215	210	
T	126	126	126	250	250	
Masa [kg]:	10,0	20,0	28,0	45,0	64,0	

WCIĄGARKA LINOWA CTF



Typ	DOR [t]	Średnica liny [mm]	Standardowa długość liny [m]	Długość dźwigni [mm]	Długość [mm]	Szerokość [mm]	Wysokość [mm]	Masa [kg/szt.]
CTF 0,8	0,8	8,3	20	800	430	63	235	8,6
CTF 1,5	1,5	11	20	800/1200	550	97	286	14,3
CTF 3,2	3,2	16	20	800/1200	660	116	350	24,8
CTF 5,4	5,4	20	20	800/1200	980	174	525	49

ZBLOCZA, KRAŻKI

- Spełniają wymagania dyrektywy maszynowej 2006/42/WE
- Znakowanie: udźwig, znak CE, nazwa producenta, numer seryjny,
- Dokumenty: deklaracja zgodności, świadectwo jakości 2.1, instrukcja użytkowania

KRAŻEK LINOWY PRZYKRĘCANY CKPB

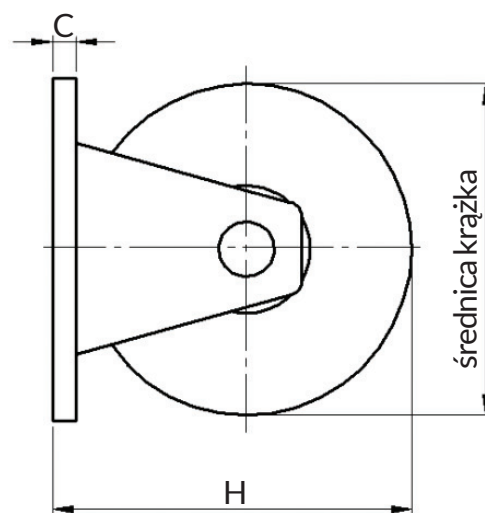
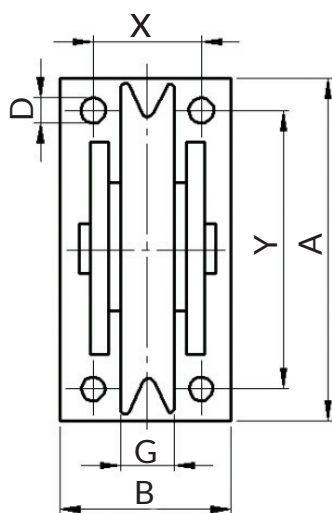
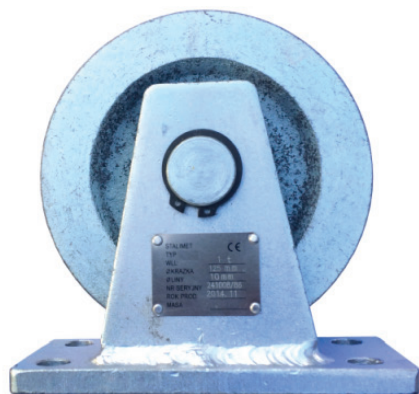

Typ	DOR [t]	Średnica krażka [mm]	Średnica liny [mm]	Wymiary [mm]								Masa [kg]
				A	B	C	H	G	D	X	Y	
CKPB 0,5	0,5	100	8	122	60	8	109	18	10	30	90	1,35
CKPB 1,0	1,0	125	10	140	60	9	138	21	12	35	110	2,2
CKPB 2,0	2,0	150	12	180	80	11	168	24	14	40,5	139,5	4,3
CKPB 3,0	3,0	200	16	230	100	15	221	30	18	50	170	8,2
CKPB 5,0	5,0	275	20	320	121	20	302	37	23	60	260	17,0

KRAŻEK LINOWY ROZBIERALNY Z HAKIEM CKHD

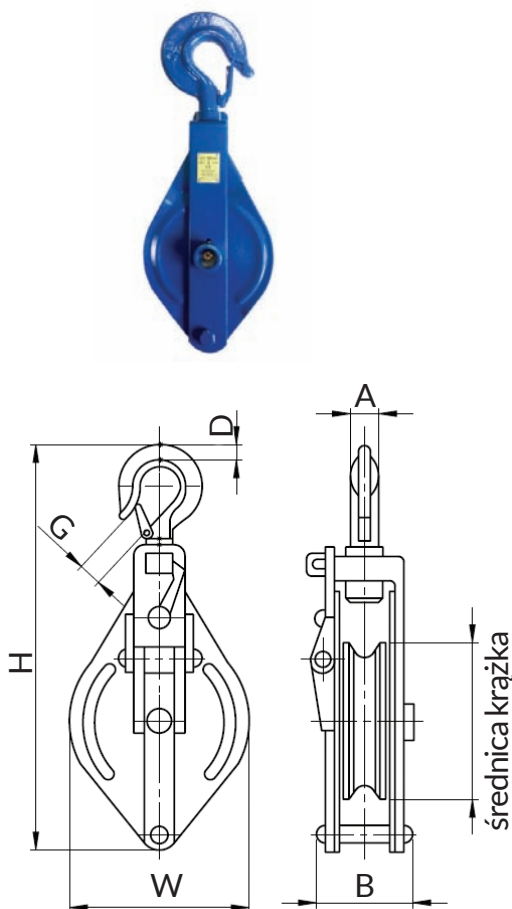

Typ	DOR [t]	Średnica krażka [mm]	Średnica liny [mm]	Wymiary [mm]						Masa [kg]
				H	W	B	D	A	G	
CKHD 0,5	0,5	75	8	270	88	41	29	17	21	1,5
CKHD 1,0	1,0	100	10	312	112	48	31	21	20	2,6
CKHD 1,5	1,5	125	13	375	140	58	38	23	21	4,6
CKHD 2,0	2,0	150	16	443	168	78	42	25	31	7,6
CKHD 3,0	3,0	180	19	498	205	83	45	30	29	11,1
CKHD 4,0	4,0	200	22	591	226	113	63	36	34	19,2
CKHD 5,0	5,0	250	25	707	276	134	63	44	37	34,2

KRAŻEK LINOWY ROZBIERALNY Z HAKIEM CKHM

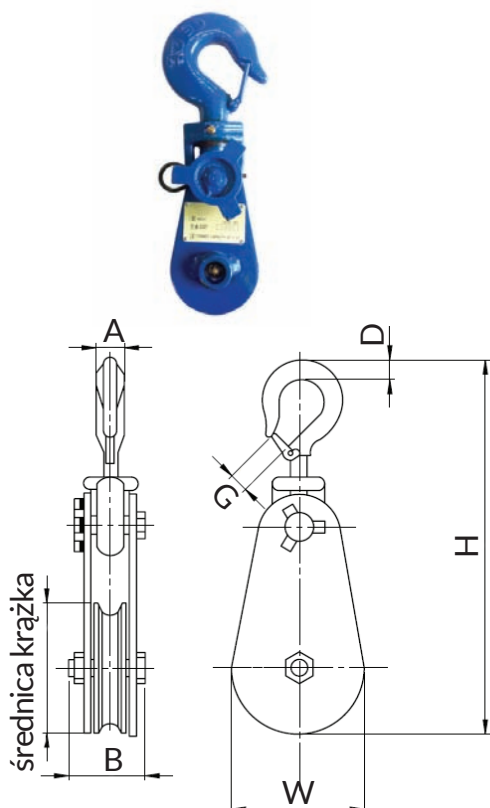

Typ	DOR [t]	Średnica krażka [mm]	Średnica liny [mm]	Wymiary [mm]						Masa [kg]
				H	W	B	D	A	G	
CKHM 2x75	2,0	75	7-9	295	83	71	32	24	23	3,7
CKHM 4x115	4,0	115	10-12	358	121	71	39	32	34	6,0
CKHM 4x150	4,0	150	16-18	412	162	71	39	33	34	8,2
CKHM 8x200	8,0	200	20-22	549	209	96	60	40	37	18,1
CKHM 10x250	10,0	250	24-26	720	260	114	66	51	55	33,7
CKHM 12x300	12,0	300	24-26	810	210	122	78	58	55	50,0
CKHM 15x350	15,0	350	26-28	810	306	130	76	56	70	51,0
CKHM 22x400	22,0	400	28-32	1050	418	142	92	71	72	110

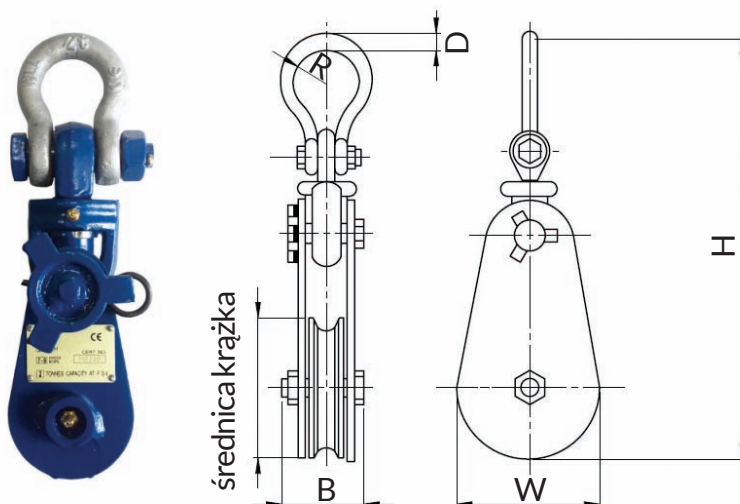
KRAŻEK LINOWY ROZBIERALNY Z SZAKŁĄ CKSZ

Typ	DOR [t]	Średnica krażka [mm]	Średnica liny [mm]	Wymiary [mm]					Masa [kg]
				H	W	B	D	R	
CKSZ 2x75	2,0	75	7-9	290	82	71	16,5	21,5	3,7
CKSZ 4x115	4,0	115	10-12	365	121	71	23,5	28	6,2
CKSZ 4x150	4,0	150	16-18	420	162	71	24	28	8,3
CKSZ 8x200	8,0	200	20-22	530	210	94	25,5	33	18,0
CKSZ 10x250	10,0	250	24-26	670	260	115	32	41	34,0
CKSZ 22x400	22,0	400	26-28	1015	413	147	54	63	114

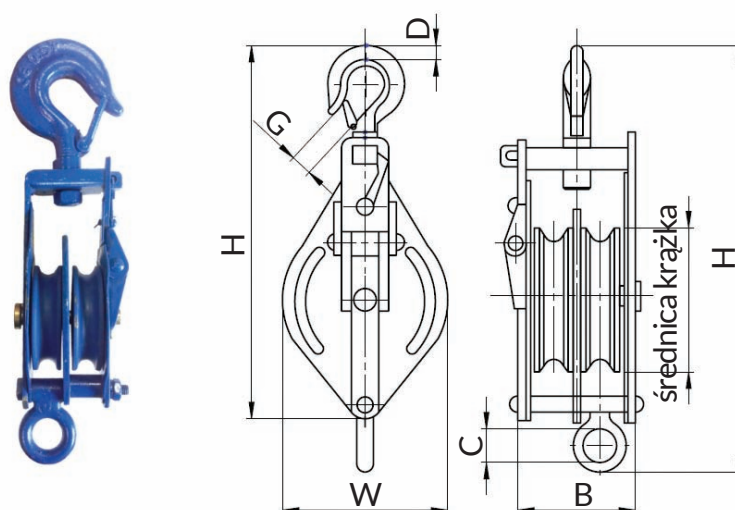
KRAŻEK LINOWY ROZBIERALNY Z HAKIEM CKDR

Typ	DOR [t]	Średnica krażka [mm]	Średnica liny [mm]	Wymiary [mm]							Masa [kg]
				H	W	B	D	A	G	C	
CKDR 1,0	1,0	100	10	347	111	91	31	21	19	21	1,2
CKDR 2,0	2,0	150	16	483	168	147	42	26	31	27,5	12,0
CKDR 4,0	4,0	200	22	650	226	171	59	36	33	27,5	29,5

TRAWERSY











- Spełniają wymagania dyrektywy maszynowej 2006/42/WE oraz zharmonizowanej normy PN-EN 13155
- Użyte materiały: stal konstrukcyjna o podwyższonej wytrzymałości zapewniająca lekką konstrukcję
- Malowane na kolor żółty, na podkładzie (możliwe inne kolory)
- Standardowo wyposażane w osprzęt klasy 8 jakości stali
- Znakowanie: udźwig, znak CE, nazwa producenta, numer seryjny, data produkcji
- Dokumenty: deklaracja zgodności, świadectwo jakości 2.1, instrukcja użytkowania
- W opcji: stojak do trawersy, trawersy o zmiennej rozpiętości wyposażone w ergonomiczne uchwyty ręczne, mechanizm wygodnego wypinania z haka suwnicy



Typy zawieszenia trawersu

U (ucho)	Z (zawiesie)	K (uszy podwójne)	G (grzebień)
A yellow CECHO beam with a single hook (U) attached to the top center.	A yellow CECHO beam with a triangular suspension system (Z) attached to the top center.	A yellow CECHO beam with two hooks (K) attached to the top ends.	A yellow CECHO beam with a comb-like attachment (G) on the top surface.

Typy zawieszania zawieszania ładunku

O	OP	H	T	TP
				
R	RP	TH	PT	PTP
				

Sposób zaczepienia ładunku

BX	CZO	COZO	zł1	zł2	zp
					

Przykładowe sposoby oznaczenia trawersów

Przykład	Typ	Udźwig [t]	Zawieszenie trawersu	Rozpiętość wzdłużna [m]	Rozpiętość poprzeczna [m]	Podaj ilość i sposób podwieszenia ładunku	Uwagi dodatkowe
1.	Trawers CT	2,0	G	3,0	-	3 CZO	
2.	Trawers CT	5,0	Z	2,5 - 5,0	-	2 zp	Długość zawiesi 4m
3.	Trawers CT	10	U	1,5 - 4,0	1,0 - 2,0	4 zł1	Długość zawiesi 1m

SUWNICE, ŻURAWIE

- Spełniają wymagania dyrektywy maszynowej 2006/42/WE
- Użyte materiały: stal konstrukcyjna o podwyższonej wytrzymałości zapewniająca lekką konstrukcję
- Malowane na kolor żółty, na podkładzie (możliwe inne kolory)
- Znakowanie: udźwig, znak CE, nazwa producenta, numer seryjny, data produkcji
- Dokumenty: deklaracja zgodności, świadectwo jakości 2.1, instrukcja użytkowania

WCIĄGARKA BRAMOWA

- Wyposażenie wciągarki zależne od wymagań Klienta.
Możliwe opcje:
 - przejazd wózka + podnoszenie = napęd ręczny,
 - przejazd wózka = napęd ręczny; podnoszenie = napęd elektryczny,
 - przejazd wózka + podnoszenie = napęd elektryczny
- W zapytaniu proszę podać: udźwig wciągarki, wymiar L, Hp, Hc

Uwaga: przejazd bramownicą możliwy jedynie bez obciążenia!

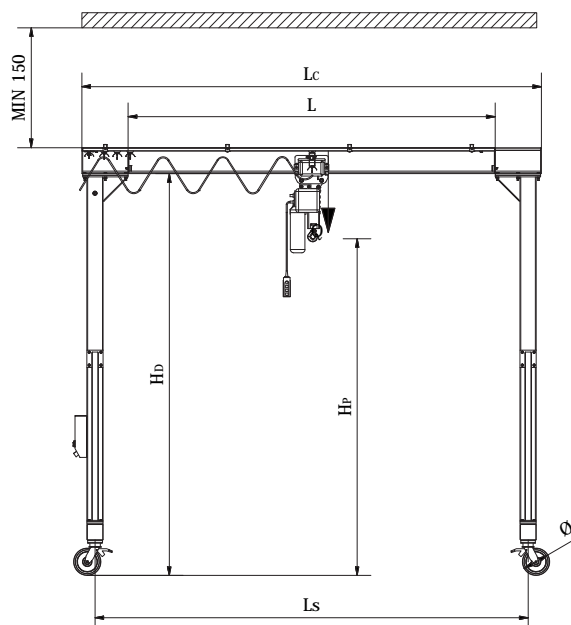

ŻURAW STACJONARNY

- Wyposażenie żurawia zależne od wymagań Klienta.
Możliwe opcje:
 - obrót ramienia + przejazd wózka + podnoszenie = napęd ręczny,
 - obrót ramienia + przejazd wózka = napęd ręczny; podnoszenie = napęd elektryczny,
 - obrót ramienia + przejazd wózka + podnoszenie = napęd elektryczny
- Opcjonalne wyposażenie: zwalniacz obrotu ramienia, ogranicznik kąta pracy ramienia
- Standardowo przygotowany do montażu na fundamencie a w opcji do montażu na posadzce
- Żurawie montowane bezpośrednio do fundamentu, dostarczane są z kompletem kotew i szablonem montażowym
- W zapytaniu proszę podać: udźwig wciągarki, wymiar L, Hp, Hc. oraz wyposażenie: ramię obrotowe, wózek, wciągnik elektryczny lub ręczny

Uwaga: analiza możliwości kotwienia żurawia w wybranej lokalizacji leży po stronie Kupującego!

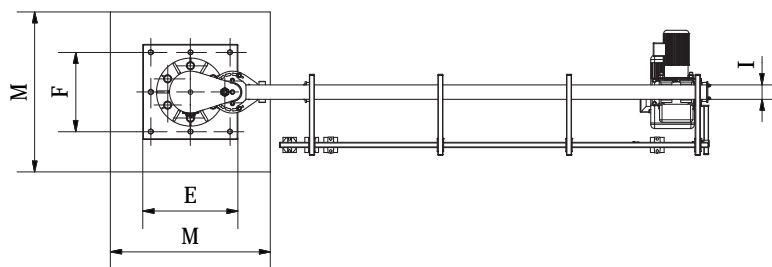
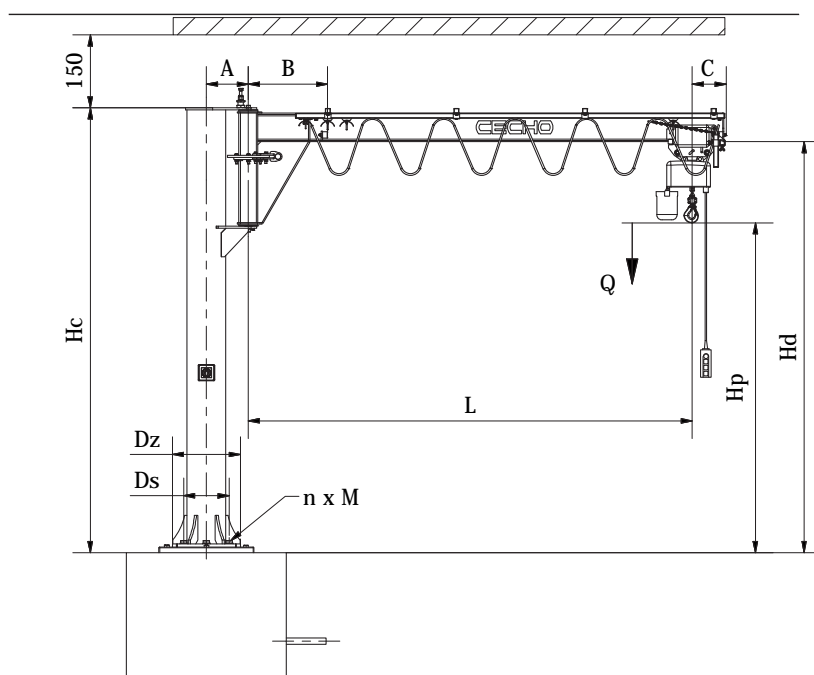
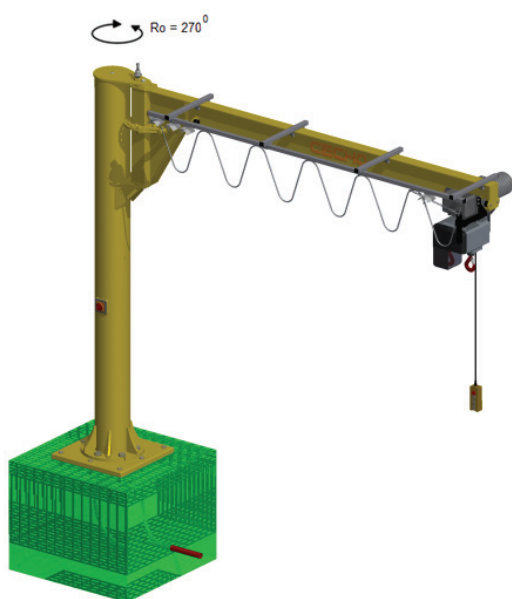

LINY STALOWE

- Spełniają wymagania aktualnej dyrektywy maszynowej i normy zharmonizowanej PN-EN 12385-1 do 5
- Dostępne liny o różnych kierunkach zwicia: lewe, prawe oraz przeciwwzite, współzwite: sZ, zZ, zS, sS
- Oferujemy liny o różnych rodzajach rdzeni w postaci: włókna naturalnego, włókna syntetycznego, splotki linowej, niezależnej liny stalowej, liny stalowej w osłonie polimeru itp.
- Posiadamy w ofercie liny stalowe ocynkowane, czarne, smarowane, w osłonie z PVC, nierdzewne, kwasoodporne itp.
- Dostarczane przez nas liny znajdują zastosowanie praktycznie w wszystkich dziedzinach przemysłu, a główne ich zastosowanie to: liny do produkcji zawiesi linowych, liny do dźwigów i żurawi, liny mocujące i kotwiące do odciągów, liny do suwnic, liny do wciągarek i wciągników, liny do wyciągów narciarskich itp.

Uwaga: niniejszy katalog prezentuje tylko najpopularniejsze i najczęściej stosowane liny. Jeżeli nie znajdziecie Państwo liny która Was interesuje, prosimy o kontakt z nami. Nasi eksperci pomogą we właściwym doborze liny, zaproponują alternatywę do drogich lin i tych wycofanych już z produkcji.

LINA STALOWA WS6X36 + FC

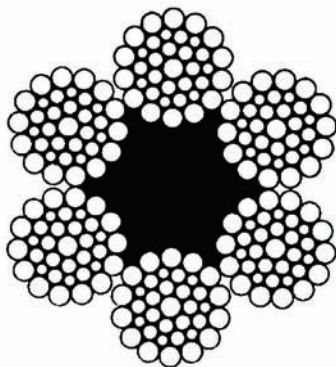

Średnica liny [mm]	Masa [kg/100m]	Minimalna siła zrywająca [kN]	
		1770 N/mm ²	1960 N/mm ²
8	23,50	37,40	41,40
9	29,70	47,30	52,40
10	36,70	58,40	64,70
11	44,40	70,70	78,30
12	52,80	84,10	93,10
13	62,00	98,70	109,00
14	71,90	114,00	127,00
16	94,00	150,00	166,00
18	119,00	189,00	210,00
20	147,00	234,00	259,00
22	178,00	283,00	313,00
24	211,00	336,00	373,00
26	248,00	395,00	437,00
28	288,00	458,00	507,00
30	330,30	526,00	582,00
32	376,00	598,00	662,00
34	424,30	675,00	748,00
36	476,00	757,00	838,00
38	529,90	843,00	934,00
40	587,00	935,00	1040,00
42	647,40	1030,00	1141,00
44	711,00	1130,00	1250,00
46	776,60	1236,00	1369,00
48	846,00	1350,00	1490,00
52	992,00	1580,00	1750,00
56	1150,00	1830,00	2030,00
60	1 320,00	214,00	2330,00

LINA STALOWA
WS6X36 + IWRC

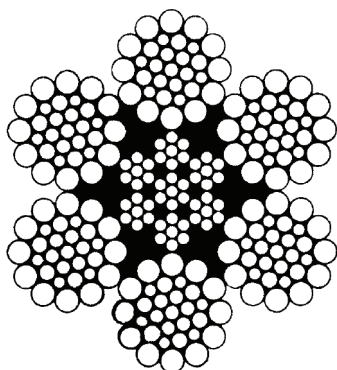

Średnica liny [mm]	Masa [kg/100m]	Minimalna siła zrywająca [kN] 1770 N/mm ²
5	8,65	13,10
6	12,50	18,8
7	17,00	25,6
8	22,10	33,4
9	28,00	42,3
10	34,60	52,2
11	41,90	63,2
12	49,80	75,2
13	58,50	88,2
14	67,80	102,00
15	77,00	118,00
16	89,00	134,0
18	112,00	169,0
20	138,00	209,0
22	167,00	253,0
24	199,00	301,0
26	234,00	353,0
28	271,00	409,0
30	311,00	470,0
32	354,00	535,0
34	400,00	604,0
36	448,00	676,0
38	500,00	76,90
40	554,00	85,20
44	670,00	103,00
48	797,00	123,00
52	936,00	144,00
56	1085,00	167,00
60	1246,00	192,00

Średnica liny [mm]	Masa [kg/100m]	Minimalna siła zrywająca [kN]	
		1770 N/mm ²	1960 N/mm ²
8	26,20	40,30	44,70
9	33,10	51,00	56,50
10	40,90	63,00	69,80
11	49,50	76,20	84,40
12	58,90	90,70	100,00
13	69,10	106,00	118,00
14	80,20	124,00	137,00
16	105,00	161,00	179,00
18	133,00	204,00	226,00
20	164,00	252,00	279,00
22	198,00	305,00	338,00
24	236,00	363,00	402,00
26	276,00	426,00	472,00
28	321,00	494,00	547,00
30	368,00	567,00	628,00
32	419,00	645,00	715,00
34	473,00	728,00	807,00
36	530,00	817,00	904,00
38	591,00	910,00	1010,00
40	654,00	1010,00	1120,00
42	721,50	1110,00	1230,00
44	792,00	1220,00	1350,00
48	942,00	1450,00	1610,00
51	1064,00	1639,00	1815,00
52	1110,00	1700,00	1890,00
56	1280,00	1980,00	2190,00
57	1329,00	2047,00	2267,00
60	1470,00	2270,00	2510,00
64	1675,00	2580,00	2858,00

LINA STALOWA
6X37 + FC

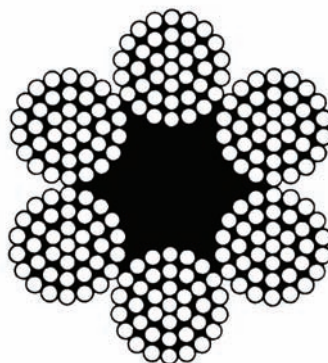

LINA STALOWA 6X19 + FC

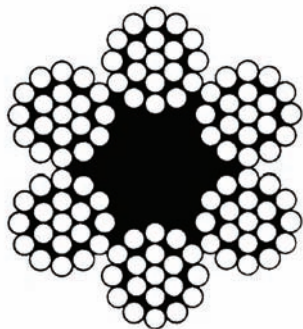

Średnica liny [mm]	Masa [kg/100m]	Minimalna siła zrywająca [kN]	
		1770 N/mm ²	1960 N/mm ²
3	3,11	4,89	5,42
4	5,54	8,69	9,63
5	8,65	13,60	15,00
6	12,50	19,60	21,70
7	17,00	26,60	29,50
8	22,10	34,80	38,50
9	28,00	44,00	48,70
10	34,60	54,30	60,20
11	41,90	65,80	72,80
12	49,80	78,30	86,70
13	58,50	91,80	101,70
14	67,80	107,00	118,00
16	88,60	139,00	154,00
18	112,00	176,00	195,00

LINA STALOWA 6X7 + FC

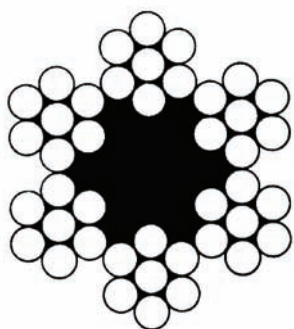

Średnica liny [mm]	Masa [kg/100m]	Minimalna siła zrywająca [kN]
		1770 N/mm ²
2	1,38	2,35
3	3,11	5,29
4	5,52	9,40
5	8,63	14,70
6	12,40	21,20
7	16,90	28,80
8	22,10	37,60
9	27,90	47,60
10	34,50	58,80
11	41,70	71,10
12	49,70	84,60
13	58,30	99,30
14	67,60	115,00
16	88,30	150,00
18	112,00	190,00
20	138,00	235,00

LINA STALOWA O OGRANICZONEJ ODKRĘTNOŚCI 19X7

Średnica liny [mm]	Masa [kg/100m]	Minimalna siła zrywająca [kN]	
		1960 N/mm ²	
4	6,4	10,29	
5	10,00	16,10	
6	14,40	23,10	
7	19,70	31,50	
8	25,70	41,10	
9	32,50	52,10	
10	40,10	64,30	
11	48,50	77,80	
12	58,00	92,60	
13	67,80	108,70	
14	79,00	126,00	
16	103,00	165,00	

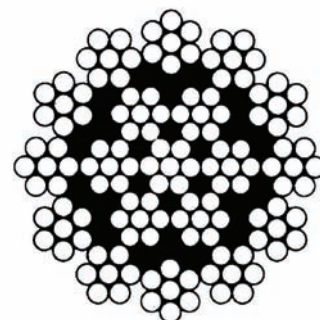

LINA STALOWA 35X7 NIEODKRĘTNA DO DŹWIGÓW I ŻURAWI

Średnica liny [mm]	Masa [kg/100m]	Minimalna siła zrywająca [kN]	
		1960 N/mm ²	2160 N/mm ²
8	29,10	45,20	48,40
9	36,80	57,20	61,20
10	45,40	70,60	75,60
11	54,90	85,40	91,50
12	65,40	102,00	109,00
13	76,70	119,00	128,00
14	89,00	138,00	148,00
16	116,00	181,00	194,00
18	147,00	229,00	245,00
20	182,00	282,00	302,00
22	220,00	342,00	366,00
24	262,00	406,00	435,00
26	307,00	476,00	511,00
28	356,00	553,00	593,00
32	465,00	723,00	774,00
36	588,00	914,00	980,00
36	588,00	914,00	979,78
38	655,60	1020,00	1091,00

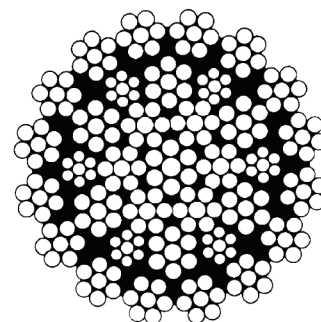

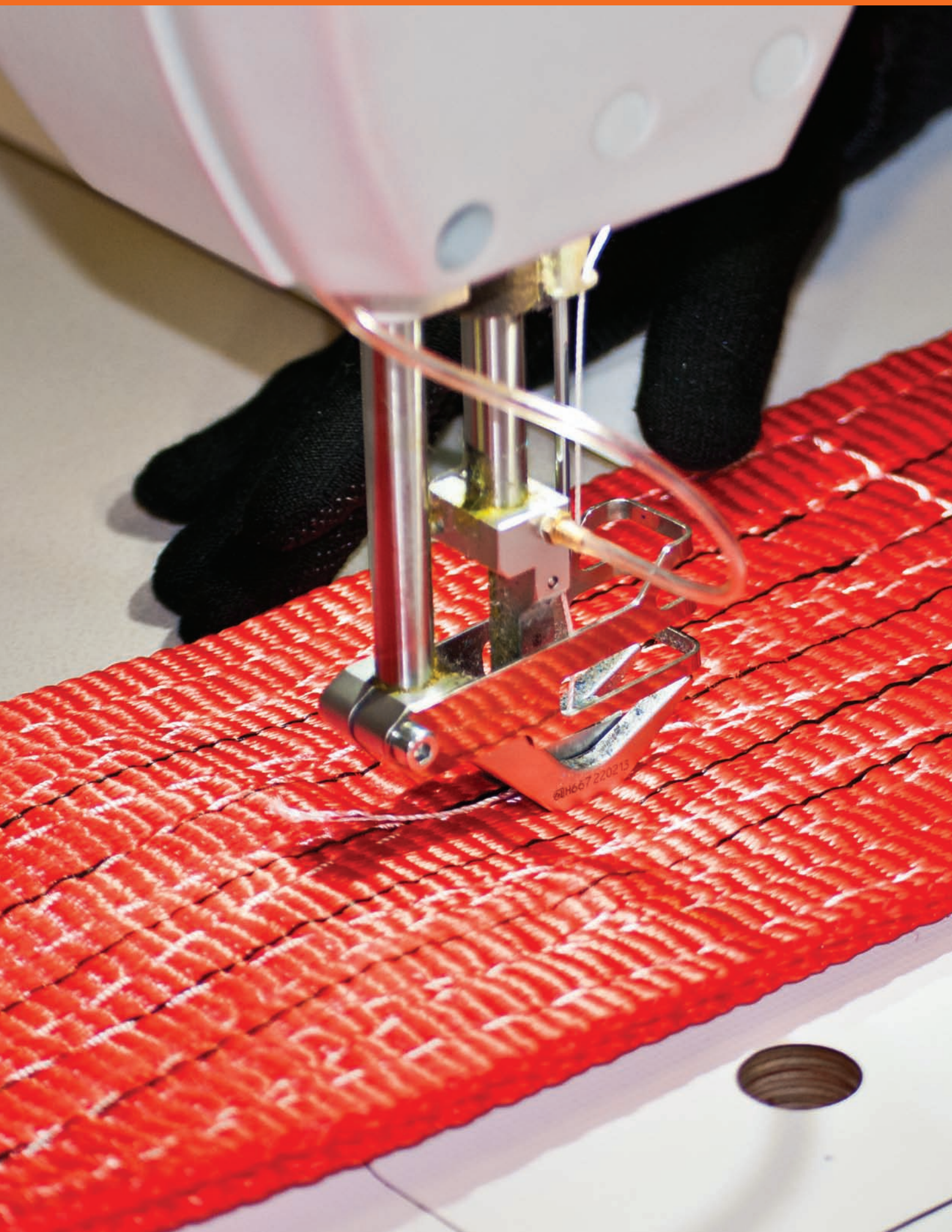



Zapraszamy do odwiedzenia



naszej strony internetowej.

WWW.CECHO.PL

CECHO

MOCNE ZAWIESIA

Cecho Spółka z o.o.
ul. gen. Mieczysława Boruty-Spiechowicza 27
43-300 Bielsko-Biała

Tel. +48 33 825 04 84
E-mail: biuro@cecho.pl



www.cecho.pl